



DA



VENTILADORES CENTRÍFUGOS
DOBLE ASPIRACIÓN

La serie de ventiladores centrífugos de mediana presión cuenta con rodetes con álabes curvos adelantados, además dispone de dos opciones de fabricación: simple y doble aspiración, con ello crea la gama de equipos denominada DA (Centrífugo de doble aspiración).

Los rodetes empleados en las series DA, son fijados a sus extremos por anillos de acero reforzado y en el caso de los rodetes de doble aspiración se unen en la parte central a un disco doble.

El diseño del álabes está concebido para minimizar las pérdidas por turbulencias del aire, obtener la máxima eficiencia en el aprovechamiento de la potencia acoplada y generar el mínimo nivel sonoro.

El balanceo dinámico que se aplica a los rodetes garantiza un adecuado funcionamiento y duración.

Las carcassas que componen a esta serie de ventiladores, están formadas por dos paredes laterales con perfiles aerodinámicos y una envolvente curva continua.

Un deflector de aire montado en la boca de descarga, evita la recirculación del aire dentro de la carcassas, de esta manera se eliminan las turbulencias y se logra un funcionamiento eficiente.

La serie DA y DAT son fabricados en lámina galvanizada resistente a la corrosión.

Entre las aplicaciones principales de estos equipos se encuentran, la transportación de aire limpio, ventilación por ductos, equipos de aire acondicionado, plenum, manejadoras de aire, cajas de filtración, etc.

VENTILADORES CENTRÍFUGOS

DA - DA/B

Ventiladores centrífugos de doble aspiración



DA

(7/7, 9/9, 10/10, 12/12, 15/15, 18/18, 20/20, 22/22, 25/25, 30/28, 36/36)

DA/B

(7/7, 9/9, 10/10, 12/12, 15/15, 18/18, 20/20, 22/22, 25/25, 30/28, 36/36)

DAT

Ventiladores centrífugos de doble aspiración tipo Twin



DAT

(10/10, 12/12, 15/15)

CARACTERÍSTICAS CONSTRUCTIVAS

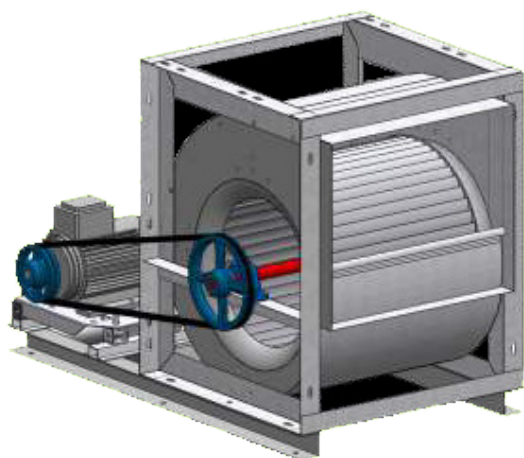

DA - DA/B

Estos equipos fabricados en lámina galvanizada resistente a la corrosión, están diseñados para brindar eficiencia y confiabilidad en aplicaciones de suministro, extracción y retorno de aire por conductos, su diseño permite obtener cuatro posiciones de descarga (cada 90°).

La serie DA integra un arreglo especial en la cual la base motor se encuentra sobre la envoltura del equipo.

La serie DA/B cuenta con un arreglo en el cual el motor descansa sobre un bastidor común al ventilador.

El modelo de mayor tamaño de esta gama, el DA 36/36, es un equipo que cuenta con características importantes de resistencia en su conjunto, para lograr un nivel inigualable en prestaciones. En donde todo el conjunto se encuentra reforzado: rodets robustos y con altos estándares de balanceo, soportes reforzados, rodamientos en carcasa industrial de larga vida útil.

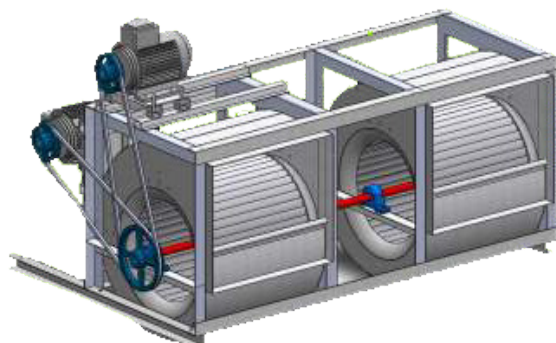

DAT

Equipos acoplados en paralelo, accionados con un solo motor, unidos mediante el mismo eje transmisión.

Disponibles en tamaños 10/10, 12/12 y 15/15.

Estos equipos representan una opción interesante para aplicaciones donde el espacio a ocupar por los ventiladores se encuentra restringido.

Fabricados con las mismas características constructivas que los equipos DA de doble aspiración.

La principal aplicación de esta opción es para montaje en plenum para manejadoras, cajas filtración, etc.

LABORATORIOS S&P Y ENSAYOS DE EQUIPOS

El grupo S&P ha consolidado cuatro laboratorios acreditados para pruebas de ventiladores: dos en América (EUA y México) y uno en Asia (Singapur) con acreditación AMCA.

Además del Centro R+D+i ubicado en Europa (España) en donde cuenta además, con un laboratorio acreditado por ENAC.

Todos los datos de caudal, presión, consumo energético, eficiencia, nivel sonoro, que se muestran en el presente catálogo, han sido evaluados y corroborados en laboratorios S&P, brindando confiabilidad en las prestaciones del equipo.

NOMENCLATURA

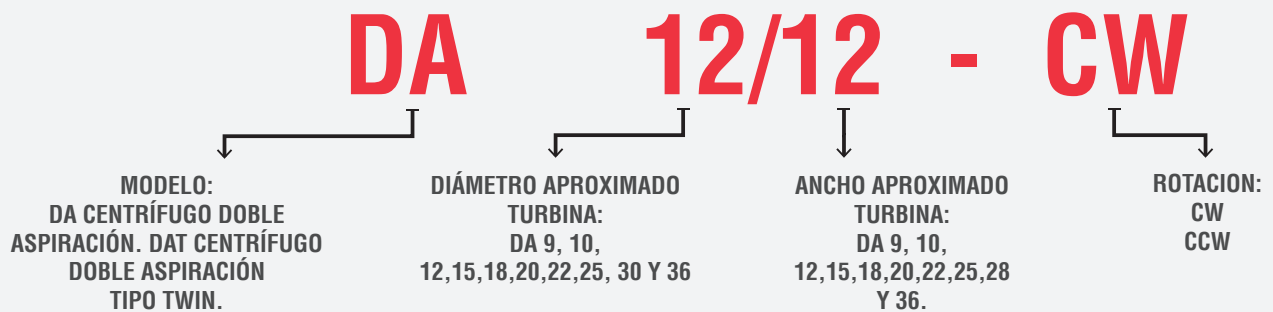

Los valores de caudal y presión están certificados para instalación tipo B: Sin ducto en la succión y ducto en la descarga. Estos valores no incluyen los efectos de accesorios. Los valores de potencia (kW/BHP) no incluyen las pérdidas por transmisión. Los datos de sonido (A - Weighted) han sido calculados por la norma AMCA 301. Los valores mostrados son medidos a la succión Lw (A) niveles de potencia sonora para instalación tipo B: Sin ducto en la succión y ducto en la descarga. No incluye el efecto de corrección por descarga en ducto. El sello de certificación AMCA no aplica para dB(A).

Performance certified is for installation type B: free inlet, ducted outlet. Performance ratings do not include the effects of appurtenances (accessories). Power ratings (kW/BHP) does not include transmission losses. The (A-weighted) sound ratings shown have been calculated per AMCA Standard 301. Values shown are for inlet Lwi(A) sound power levels for installation type B: free inlet, ducted outlet. Ratings do not include the effect of duct end correction. The AMCA Certified Ratings Seal does not apply to dB(A).



FACTORES DE CORRECCIÓN DE DENSIDAD DEL AIRE POR ALTITUD Y TEMPERATURA

Los valores que se presentan en las tablas de selección de este catálogo se refieren a condiciones estándar de operación, 0 metros s.n.m. (0 ft.s.n.m.), 20 °C (70 °F), densidad del aire: 1.2 kg/m³ (0.075 lb/ft³). Se deben aplicar factores de corrección cuando la temperatura, humedad, altura, composición del gas o cualquier combinación de estas causas provoque un cambio de la densidad en más de un 5% con respecto a la densidad estándar.

*La siguiente tabla muestra los valores de los factores de corrección aplicables.

Altitud (metros snm)	Temperatura (°Centígrados)						
	21	30	38	65	93	149	204
0	1.000	0.971	0.946	0.876	0.803	0.697	0.616
305	0.964	0.936	0.912	0.844	0.774	0.672	0.594
610	0.930	0.903	0.880	0.815	0.747	0.648	0.573
914	0.896	0.870	0.848	0.785	0.720	0.624	0.552
1219	0.864	0.839	0.818	0.757	0.694	0.604	0.532
1524	0.832	0.808	0.787	0.729	0.668	0.580	0.513
1829	0.801	0.778	0.758	0.702	0.643	0.558	0.493
2134	0.772	0.750	0.73	0.676	0.620	0.538	0.476
2438	0.743	0.722	0.703	0.651	0.596	0.518	0.458
2743	0.714	0.694	0.676	0.626	0.573	0.498	0.440
3048	0.688	0.668	0.651	0.602	0.552	0.480	0.424
4572	0.564	0.548	0.534	0.494	0.453	0.393	0.347
6096	0.460	0.447	0.435	0.403	0.369	0.321	0.283

Para estos ventiladores, la temperatura máxima del flujo de aire a manejar es de 80°C. Para aplicaciones donde la temperatura sea mayor, favor de comunicarse al departamento técnico Soller & Palau.

Ejemplo de aplicación de los factores de corrección

Un ventilador es seleccionado para suministrar 19,000 m³/hr (11,176 CFM) bajo una presión estática de 101.6 mm c.a. (4.0 in wg), a una altitud de 1,524 metros s.n.m. y operando a una temperatura de 93 °C.

Para determinar las condiciones de operación del ventilador:

1.- Se debe precisar el factor de corrección de la tabla: FACTORES DE CORRECCIÓN DE DENSIDAD DEL AIRE. En este caso el factor es: 0.668

2.- Divida la presión estática determinada entre el Factor de Corrección. 101.6 mm c.a. / 0.668 = 152.09 mm c.a.

3.- Multiplique la potencia al freno que requiere el ventilador (en este ejemplo: 14.5 BHP) por el mismo factor de corrección (0.668). 14.5 BHP x 0.668 = 9.686 BHP

4.- El ventilador seleccionado presentará las siguientes condiciones de operación: 19,000 m³/hr (11,176 CFM), 152.09 mm c.a. (5.98 in wg), 9.686 BHP y 1,731 r.p.m.

Ejemplo de selección para equipos centrífugos modelo DA

Ejemplo:
Modelo DA-22/22
Caudal: 16650 m³/hr (9794 CFM)
PE: 57 mm c.a. (2.24 in w.g.)
BHP: 6.5
Lw: 87 dB
RPM: 700

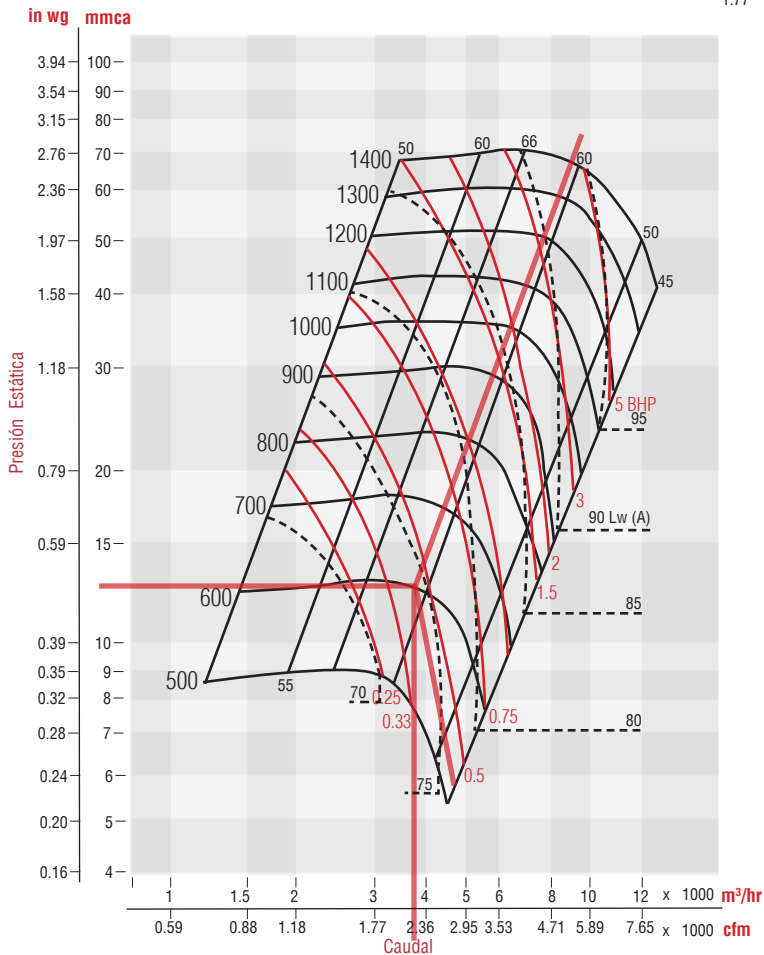
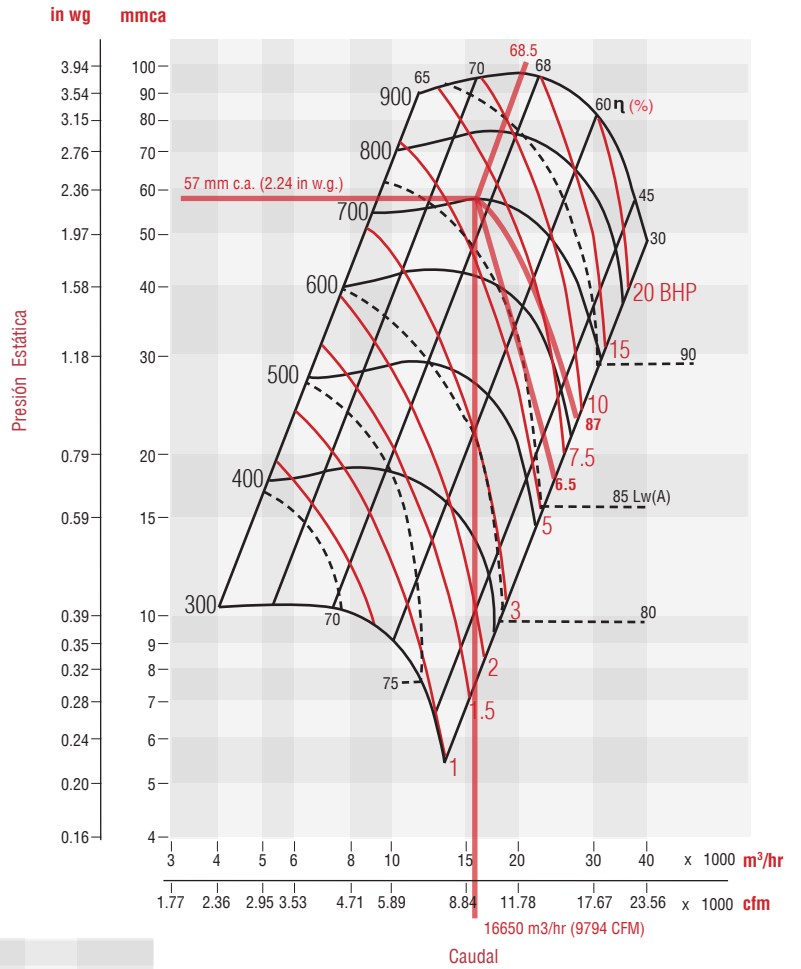

Ejemplo de selección para equipos centrífugos modelo DAT

Para seleccionar un equipo modelo Twin fan, use las curvas del modelo DA con los siguientes factores:

- Caudal x 2
- Potencia absorbida x 2.15
- Velocidad de giro x 1.05
- Nivel sonoro: + 3 dB

Ejemplo:

Modelo DAT-12/12
Partiendo de un DA-12/12 con la siguiente selección:

- Caudal: 3850 m³/hr (2265 CFM)
- PE: 12 mm c.a. (0.472 in w.g.)
- BHP: 0.47
- Lw: 74 dB
- RPM: 600

El equipo DAT-12/12 tendrá el siguiente desempeño:

- Caudal: 7700 m³/hr (4529 CFM)

VENTILADORES

DA

Centrífugos
Alabes Adelantados

DOBLE ASPIRACIÓN



CARACTERÍSTICAS PRINCIPALES DA 7/7

DA 7/7

RPM	PRESIÓN ESTÁTICA mmca / inwg																							
	4.76 mm / 0.187"		6.35 mm / 0.250"		7.94 mm / 0.312"		9.52 mm / 0.375"		11.11 mm / 0.437"		12.70 mm / 0.500"		15.40 mm / 0.625"		17.46 mm / 0.687"		19.05 mm / 0.750"		20.63 mm / 0.812"		23.82 mm / 0.937"		25.40 mm / 1.000"	
	CFM m³/hr	BHP dB (A)	CFM m³/hr	BHP dB (A)	CFM m³/hr	BHP dB (A)	CFM m³/hr	BHP dB (A)	CFM m³/hr	BHP dB (A)	CFM m³/hr	BHP dB (A)	CFM m³/hr	BHP dB (A)	CFM m³/hr	BHP dB (A)	CFM m³/hr	BHP dB (A)	CFM m³/hr	BHP dB (A)	CFM m³/hr	BHP dB (A)	CFM m³/hr	BHP dB (A)
800	608	0.06	542	0.06																				
	1032	71	921	70																				
850	666	0.07	611	0.08	533	0.06																		
	1131	72	1039	71	905	70																		
950	777	0.11	734	0.12	682	0.09	617	0.09	478	0.07														
	1319	75	1248	73	1158	73	1049	72	812	69														
1050	884	0.15	847	0.17	806	0.13	760	0.15	704	0.12	624	0.11												
	1501	77	1440	76	1369	75	1292	74	1195	74	1061	73												
1150	988	0.21	955	0.23	920	0.18	883	0.21	841	0.16	793	0.20	637	0.14										
	1678	79	1624	78	1562	77	1501	77	1428	76	1348	76	1082	73										
1250	1090	0.27	1060	0.30	1029	0.25	997	0.28	962	0.22	925	0.30	834	0.20	771	0.19	660	0.17						
	1851	81	1802	79	1747	79	1695	79	1633	78	1573	78	1416	77	1309	76	1122	75						
1350	1190	0.35	1216	0.41	1136	0.32	1107	0.39	1077	0.29	1107	0.40	974	0.26	932	0.25	883	0.3	820	0.23				
	2021	82	2067	81	1929	80	1880	81	1829	80	1882	80	1654	79	1583	78	1501	78	1392	77				
1450	1290	0.45	1264	0.49	1240	0.41	1213	0.46	1187	0.38	1159	0.40	1098	0.34	1065	0.33	1029	0.37	988	0.31	881	0.29	788	0.27
	2190	84	2149	83	2106	82	2062	82	2016	82	1970	82	1864	81	1808	81	1749	81	1678	80	1496	79	1340	78
1500	1340	0.50	1315	0.54	1291	0.46	1266	0.52	1241	0.43	1214	0.50	1158	0.39	1127	0.38	1094	0.43	1058	0.35	972	0.33	915	0.34
	2233	84	2236	83	2192	83	2152	83	2107	83	2064	82	1966	82	1861	82	1860	81	1737	81	1577	80	1556	80
1550	1389	0.55	1365	0.60	1342	0.51	1318	0.57	1294	0.48	1268	0.60	1215	0.44	1187	0.42	1157	0.49	1124	0.40	1050	0.38	1005	0.41
	2359	85	2321	84	2279	84	2241	84	2197	83	2156	83	2063	83	2016	83	1967	82	1909	82	1783	81	1709	81

RPM	PRESIÓN ESTÁTICA mmca / inwg																							
	26.98 mm / 1.062"		28.58 mm / 1.125"		31.75 mm / 1.250"		34.92 mm / 1.375"		38.10 mm / 1.500"		39.62 mm / 1.562"		44.45 mm / 1.750"		49.22 mm / 1.938"		53.97 mm / 2.125"		58.73 mm / 2.312"		61.92 mm / 2.437"		69.85 mm / 2.750"	
	CFM m³/hr	BHP dB (A)	CFM m³/hr	BHP dB (A)	CFM m³/hr	BHP dB (A)	CFM m³/hr	BHP dB (A)	CFM m³/hr	BHP dB (A)	CFM m³/hr	BHP dB (A)	CFM m³/hr	BHP dB (A)	CFM m³/hr	BHP dB (A)	CFM m³/hr	BHP dB (A)	CFM m³/hr	BHP dB (A)	CFM m³/hr	BHP dB (A)	CFM m³/hr	BHP dB (A)
1600	1040	0.40	989	0.39																				
	1766	82	1679	82																				
1650	1118	0.46	1076	0.45	965	0.41																		
	1898	83	1827	82	1639	81																		
1750	1256	0.57	1225	0.56	1152	0.53	1055	0.50																
	2133	84	2080	84	1956	84	1791	83																
1850	1383	0.70	1356	0.69	1298	0.66	1231	0.64	1145	0.65	1090	0.59												
	2348	86	2302	86	2204	85	2090	85	1947	84	1851	84												
1950	1502	0.85	1479	0.83	1430	0.81	1375	0.78	1312	0.85	1277	0.74	1135	0.71										
	2550	87	2511	87	2428	87	2335	86	2230	86	2168	86	1930	85										
2050	1618	1.02	1597	1.00	1553	0.97	1505	0.94	1454	1.05	1426	0.89	1329	0.94	1190	0.79								
	2747	89	2712	88	2637	88	2555	88	2472	88	2421	87	2259	87	2021	86								
2150	1729	1.21	1710	1.19	1670	1.15	1628	1.12	1583	1.27	1560	1.07	1481	1.17	1387	0.98	1255	0.91						
	2936	90	2904	90	2836	89	2764	89	2691	89	2649	89	2518	88	2355	88	2131	87						
2250	1839	1.41	1821	1.39	1785	1.35	1746	1.32	1706	1.52	1685	1.26	1618	1.42	1541	1.17	1450	1.12	1325	1.05	1178	0.97		
	3123	91	3092	91	3031	91	2965	90	2900	90	2861	90	2751	90	2617	89	2462	89	2250	88	2000	87		
2350	1947	1.65	1930	1.62	1896	1.58	1861	1.54	1824	1.78	1805	1.48	1745	1.68	1679	1.38	1605	1.33	1517	1.28	1445	1.24		
	3306	92	3277	92	3219	92	3160	92	3101	91	3065	91	2967	91	2851	91	2725	90	2576	90	2454	89		
2400	2000	1.77	1984	1.75	1951	1.70	1917	1.66	1881	1.92	1863	1.60	1806	1.82	1744	1.49	1676	1.44	1597	1.39	1536	1.35	1295	1.20
	3396	93	3369	93	3313	92	3255	92	3198	92	3163	92	3070	92	2961	91	2846	91	2712	90	2608	90	2202	88

Condiciones Estándar: 0 m.s.n.m. y 20 °C



Los valores de caudal y presión están certificados para instalación tipo B: Sin ducto en la succión y ducto en la descarga. Estos valores no incluyen los efectos de accesorios. Los valores de potencia (BHP) no incluyen las pérdidas por transmisión.

Performance certified is for installation type B: free inlet, ducted outlet. Performance ratings does not include the effects of appurtenances (accessories). Power ratings (kW/BHP) does not include transmission losses.

CURVA CARACTERÍSTICA DA 7/7

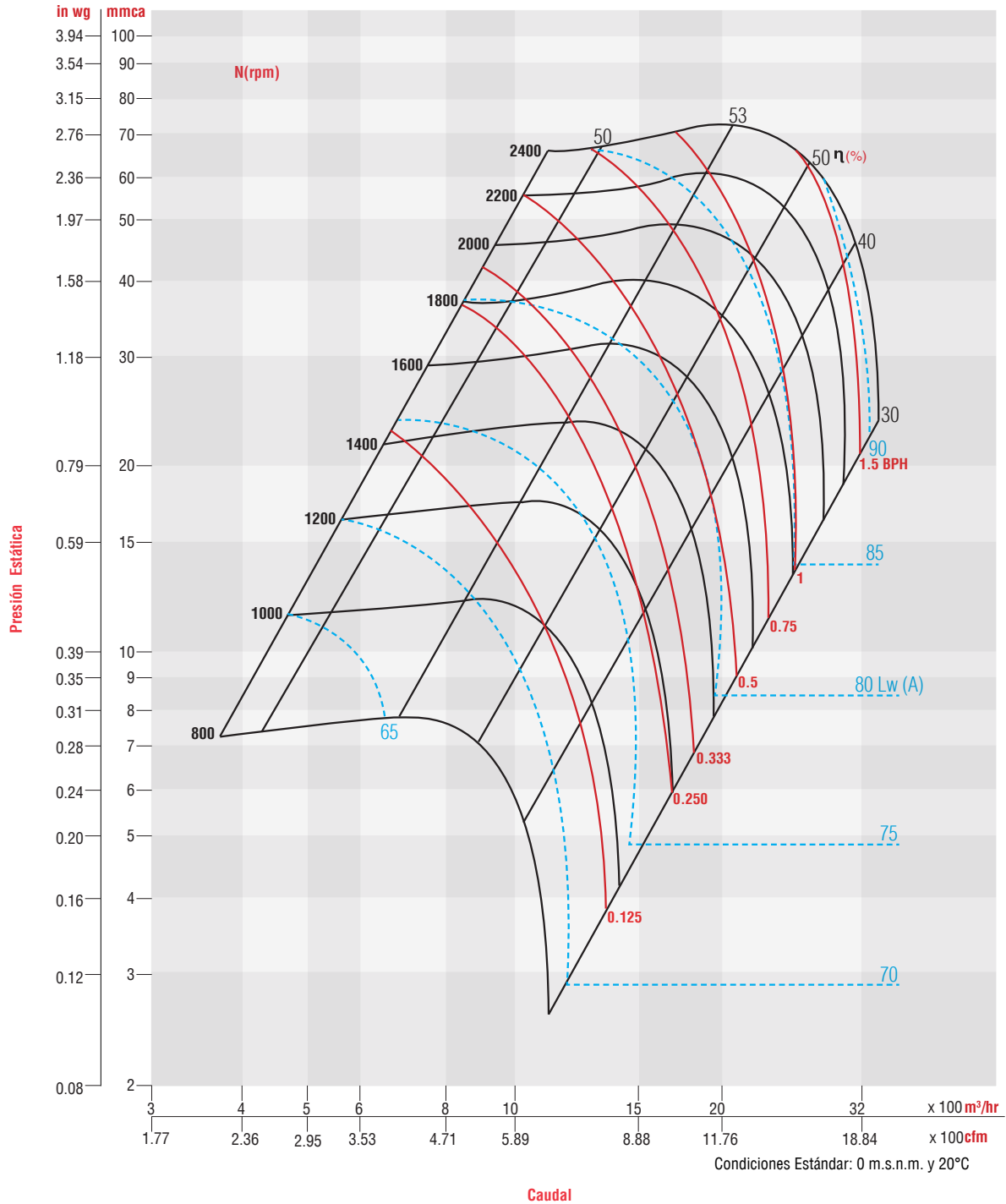

Los valores de caudal y presión están certificados para instalación tipo B: Sin ducto en la succión y ducto en la descarga. Estos valores no incluyen los efectos de accesorios. Los valores de potencia (BHP) no incluyen las pérdidas por transmisión.

Performance certified is for installation type B: free inlet, ducted outlet. Performance ratings does not include the effects of appurtenances (accessories). Power ratings (kW/BHP) does not include transmission losses.

CARACTERÍSTICAS PRINCIPALES DA 9/9

DA 9/9

RPM	PRESIÓN ESTÁTICA mmca / inwg																							
	6.35 mm / 0.250"		9.52 mm / 0.375"		11.11 mm / 0.437"		12.70 mm / 0.500"		15.88 mm / 0.625"		19.05 mm / 0.750"		22.22 mm / 0.875"		23.81 mm / 0.937"		25.40 mm / 1.000"		31.75 mm / 1.250"		34.92 mm / 1.375"		38.10 mm / 1.500"	
	CFM	BHP	CFM	BHP	CFM	BHP	CFM	BHP	CFM	BHP	CFM	BHP	CFM	BHP	CFM	BHP	CFM	BHP	CFM	BHP	CFM	BHP	CFM	BHP
	m³/hr	dB (A)	m³/hr	dB (A)	m³/hr	dB (A)	m³/hr	dB (A)	m³/hr	dB (A)	m³/hr	dB (A)	m³/hr	dB (A)	m³/hr	dB (A)	m³/hr	dB (A)	m³/hr	dB (A)	m³/hr	dB (A)	m³/hr	dB (A)
700	1359	0.19	982	0.12																				
	2308	71	1669	68																				
750	1517	0.25	1267	0.19	995	0.14																		
	2576	73	2154	72	1690	69																		
850	1813	0.40	1640	0.34	1530	0.31	1389	0.26																
	3078	77	2788	76	2598	74	2361	72																
950	2092	0.59	1954	0.53	1874	0.49	1786	0.46	1551	0.37														
	3552	79	3322	79	3182	78	3036	76	2634	76														
1050	2363	0.82	2246	0.76	2181	0.72	2113	0.69	1954	0.61	1763	0.51	1196	0.31										
	4012	82	3818	81	3703	81	3592	79	3318	79	2997	77	2031	74										
1150	2629	1.10	2526	1.04	2470	1.00	2413	0.96	2287	0.88	2140	0.80	1954	0.69	1830	0.63	1659	0.54						
	4464	84	4294	84	4194	83	4102	82	3883	82	3638	80	3318	80	3107	79	2820	77						
1250	2890	1.44	2798	1.37	2749	1.33	2699	1.29	2593	1.21	2475	1.13	2339	1.03	2262	0.98	2176	0.92						
	4907	86	4757	86	4668	85	4588	84	4403	84	4208	83	3972	83	3841	82	3699	81						
1350	3149	1.84	3065	1.76	3021	1.72	2977	1.69	2883	1.60	2783	1.51	2672	1.42	2612	1.37	2549	1.32	2225	1.07	1957	0.89		
	5347	88	5211	87	5130	87	5061	86	4895	86	4731	86	4537	85	4435	85	4333	84	3778	82	3323	81		
1400	3277	2.06	3197	1.99	3156	1.95	3113	1.90	3025	1.82	2931	1.73	2829	1.64	2774	1.59	2717	1.54	2443	1.30	2256	1.15	1963	0.95
	5564	88	5435	88	5359	88	5292	87	5136	87	4983	87	4804	86	4710	86	4619	85	4148	84	3831	83	3337	81
1450	3405	2.30	3329	2.22	3289	2.18	3249	2.14	3165	2.05	3076	1.96	2981	1.87	2930	1.82	2878	1.77	2637	1.54	2486	1.41	2292	1.24
	5782	89	5659	89	5585	88	5523	88	5374	88	5229	88	5062	87	4975	87	4893	87	4478	85	4221	84	3896	84

RPM	PRESIÓN ESTÁTICA mmca / inwg																							
	28.57 mm / 1.125"		31.75 mm / 1.250"		38.10 mm / 1.500"		44.45 mm / 1.750"		50.80 mm / 2.000"		57.15 mm / 2.250"		60.32 mm / 2.375"		63.50 mm / 2.500"		69.85 mm / 2.750"		76.20 mm / 3.000"		88.90 mm / 3.500"		96.85 mm / 3.813"	
	CFM	BHP	CFM	BHP	CFM	BHP	CFM	BHP	CFM	BHP	CFM	BHP	CFM	BHP	CFM	BHP	CFM	BHP	CFM	BHP	CFM	BHP	CFM	BHP
	m³/hr	dB (A)	m³/hr	dB (A)	m³/hr	dB (A)	m³/hr	dB (A)	m³/hr	dB (A)	m³/hr	dB (A)	m³/hr	dB (A)	m³/hr	dB (A)	m³/hr	dB (A)	m³/hr	dB (A)	m³/hr	dB (A)	m³/hr	dB (A)
1500	2931	1.91	2817	1.79	2534	1.52	2000	1.09																
	4977	88	4783	88	4303	87	3400	81																
1550	3091	2.18	2987	2.06	2742	1.80	2385	1.46																
	5249	89	5072	89	4656	88	4055	84																
1650	3398	2.76	3309	2.65	3110	2.40	2864	2.11	2507	1.73														
	5770	91	5619	90	5281	90	4869	87	4262	85														
1750	3692	3.42	3614	3.31	3443	3.06	3245	2.79	3003	2.47	2659	2.06	2358	1.75										
	6269	92	6137	92	5846	91	5517	90	5105	89	4520	87	4004	88										
1850	3979	4.17	3908	4.05	3756	3.81	3588	3.54	3394	3.24	3159	2.90	3014	2.70	2835	2.47								
	6756	94	6636	93	6378	93	6100	92	5770	91	5370	90	5118	91	4820	88								
1950	4259	5.00	4194	4.88	4057	4.63	3908	4.37	3743	4.08	3555	3.76	3449	3.59	3330	3.40	3030	2.95	2409	2.17				
	7232	95	7121	95	6889	94	6644	94	6363	93	6044	92	5856	93	5661	91	5145	91	4095	88				
2025	4466	5.69	4404	5.57	4276	5.31	4139	5.04	3989	4.76	3823	4.45	3732	4.28	3633	4.11	3404	3.71	3096	3.23				
	7583	96	7478	96	7261	95	7028	95	6773	94	6491	94	6337	94	6169	93	5780	93	5257	91				
2100	4670	6.43	4612	6.30	4491	6.05	4363	5.78	4226	5.49	4076	5.18	3995	5.02	3909	4.85	3717	4.48	3487	4.07	2393	2.47		
	7930	97	7831	97	7626	96	7417	96	7184	95	6929	95	6784	95	6645	95	6311	94	5928	93	4068	89		
2150	4806	6.95	4749	6.83	4633	6.57	4510	6.29	4379	6.00	4238	5.70	4162	5.54	4083	5.37	3909	4.62	3706	4.62	3093	3.55		
	8161	97	8064	97	7867	97	7667	97	7444	96	7205	96	7067	96	6941	95	6637	95	6300	94	5258	92		
2200	4940	7.50	4886	7.38	4774	7.11	4656	6.84	4530	6.55	4396	6.24	4325	6.08	4251	5.92	4091	5.57	3909	5.19	3419	4.24	2748	3.16
	8388	98	8296	98	8106	97	7915	97	7701	97	7473	97	7344	96	7227	96	6947	96	6645	95	5812	94	4666	92

Condiciones Estándar: 0 m.s.n.m. y 20 °C



Los valores de caudal y presión están certificados para instalación tipo B: Sin ducto en la succión y ducto en la descarga. Estos valores no incluyen los efectos de accesorios. Los valores de potencia (BHP) no incluyen las pérdidas por transmisión.

Performance certified is for installation type B: free inlet, ducted outlet. Performance ratings does not include the effects of appurtenances (accessories). Power ratings (kW/BHP) does not include transmission losses.

CURVA CARACTERÍSTICA DA 9/9

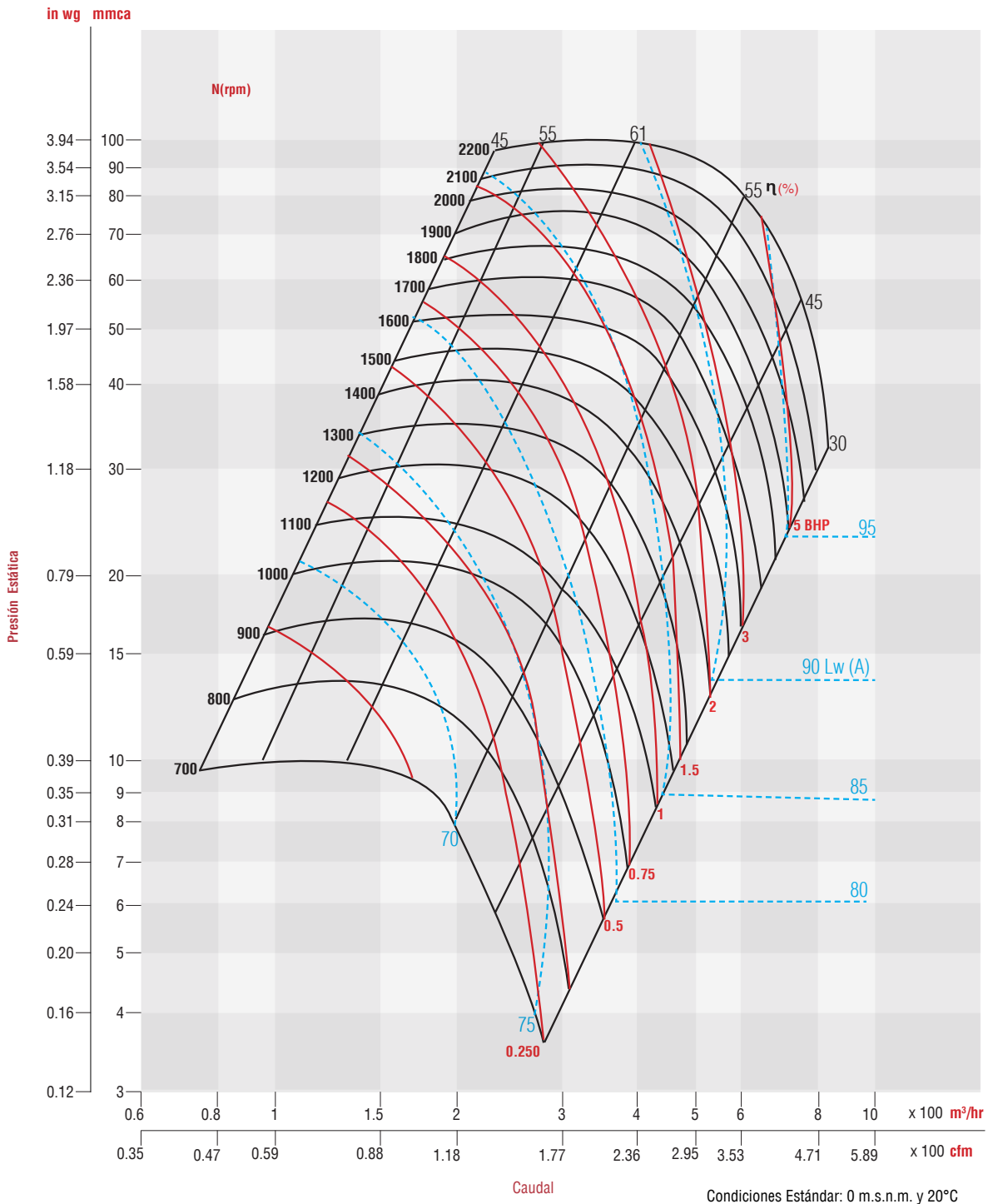

Los valores de caudal y presión están certificados para instalación tipo B: Sin ducto en la succión y ducto en la descarga. Estos valores no incluyen los efectos de accesorios. Los valores de potencia (BHP) no incluyen las pérdidas por transmisión.

Performance certified is for installation type B: free inlet, ducted outlet. Performance ratings does not include the effects of appurtenances (accessories). Power ratings (kW/BHP) does not include transmission losses.

CARACTERÍSTICAS PRINCIPALES DA 10/10

DA 10/10

RPM	PRESIÓN ESTÁTICA mmca / inwg																							
	6.35 mm / 0.250"		9.52 mm / 0.375"		12.70mm / 0.500"		14.28 mm / 0.563"		17.46 mm / 0.688"		19.05mm / 0.750"		20.63 mm / 0.812"		23.81 mm / 0.937"		25.40 mm / 1.000"		28.57 mm / 1.125"		31.75 mm / 1.250"		34.92 mm / 1.375"	
	CFM m³/hr	BHP dB (A)	CFM m³/hr	BHP dB (A)	CFM m³/hr	BHP dB (A)	CFM m³/hr	BHP dB (A)	CFM m³/hr	BHP dB (A)	CFM m³/hr	BHP dB (A)	CFM m³/hr	BHP dB (A)	CFM m³/hr	BHP dB (A)	CFM m³/hr	BHP dB (A)	CFM m³/hr	BHP dB (A)	CFM m³/hr	BHP dB (A)	CFM m³/hr	BHP dB (A)
600	1721	0.22																						
	2926	74																						
650	1931	0.30	1690	0.24																				
	3283	76	2873	73																				
750	2322	0.48	2173	0.44	1948	0.37	1727	0.3																
	3947	80	3694	79	3312	76	2932	74																
850	2693	0.72	2580	0.68	2440	0.63	2351	0.59	2091	0.49	1714	0.35												
	4578	83	4386	82	4148	81	3992	80	3551	78	2914	74												
950	3054	1.03	2962	0.99	2855	0.94	2794	0.91	2648	0.84	2559	0.79	2446	0.74										
	5192	86	5035	85	4854	85	4744	84	4496	83	4350	82	4153	81										
1050	3409	1.41	3331	1.36	3243	1.32	3195	1.29	3087	1.22	3027	1.19	2959	1.15	2796	1.05	2690	0.99	2314	0.77				
	5795	88	5663	88	5513	87	5425	87	5242	86	5146	86	5024	85	4748	84	4573	84	3929	81				
1125	3673	1.74	3602	1.7	3524	1.65	3482	1.62	3391	1.56	3342	1.53	3288	1.49	3166	1.41	3096	1.36	2921	1.24	2648	1.06		
	6244	90	6123	90	5991	89	5912	89	5758	88	5681	88	5583	88	5376	87	5263	87	4960	86	4496	84		
1175	3849	2.00	3781	1.95	3709	1.90	3670	1.87	3587	1.81	3542	1.78	3494	1.75	3389	1.67	3330	1.62	3193	1.52	3014	1.39	2730	1.18
	6543	91	6428	91	6305	90	6232	90	6091	90	6021	90	5933	89	5755	89	5661	88	5422	88	5118	87	4636	85
1225	4023	2.27	3960	2.22	3892	2.17	3855	2.14	3779	2.08	3738	2.05	3695	2.02	3601	1.94	3550	1.90	3434	1.81	3296	1.70	3115	1.55
	6839	92	6732	92	6616	91	6546	91	6417	91	6355	91	6274	90	6114	90	6035	90	5831	89	5597	89	5289	88
1250	4110	2.41	4048	2.37	3982	2.32	3947	2.29	3873	2.23	3834	2.20	3793	2.16	3704	2.09	3656	2.05	3549	1.96	3426	1.85	3266	1.72
	6987	92	6882	92	6769	92	6702	92	6576	91	6518	91	6441	91	6289	90	6215	90	6026	90	5817	90	5546	89

RPM	PRESIÓN ESTÁTICA mmca / inwg																							
	38.10 mm / 1.500"		41.27 mm / 1.625"		44.45 mm / 1.750"		46.04 mm / 1.812"		49.21 mm / 1.937"		50.80 mm / 2.000"		53.97 mm / 2.125"		57.15 mm / 2.250"		63.50 mm / 2.500"		69.85 mm / 2.750"		76.20 mm / 3.000"		84.13 mm / 3.312"	
	CFM m³/hr	BHP dB (A)	CFM m³/hr	BHP dB (A)	CFM m³/hr	BHP dB (A)	CFM m³/hr	BHP dB (A)	CFM m³/hr	BHP dB (A)	CFM m³/hr	BHP dB (A)	CFM m³/hr	BHP dB (A)	CFM m³/hr	BHP dB (A)	CFM m³/hr	BHP dB (A)	CFM m³/hr	BHP dB (A)	CFM m³/hr	BHP dB (A)	CFM m³/hr	BHP dB (A)
1300	3379	1.92	3165	1.73	2687	1.32																		
	5744	89	5374	88	4568	84																		
1325	3520	2.10	3343	1.94	3073	1.69	2787	1.44																
	5984	90	5676	89	5224	87	4732	85																
1375	3777	2.48	3641	2.34	3469	2.16	3358	2.05	2987	1.69														
	6421	91	6182	91	5897	90	5702	89	5072	87														
1425	4014	2.87	3901	2.74	3768	2.60	3690	2.51	3497	2.30	3368	2.16												
	6824	93	6624	92	6406	92	6266	91	5938	90	5726	90												
1475	4238	3.28	4140	3.16	4030	3.03	3967	2.96	3825	2.79	3742	2.69	3525	2.44	3076	1.96								
	7205	94	7030	94	6851	93	6736	93	6495	92	6361	92	5985	91	5229	88								
1525	4452	3.71	4366	3.60	4270	3.48	4218	3.42	4102	3.27	4037	3.19	3886	3.00	3688	2.75								
	7559	95	7413	95	7250	94	7162	94	6965	94	6855	93	6598	93	6262	92								
1575	4660	4.17	4582	4.07	4497	3.95	4451	3.89	4352	3.76	4299	3.69	4178	3.52	4035	3.33								
	7913	96	7780	96	7636	95	7558	95	7390	95	7300	95	7094	94	6851	94								
1650	4963	4.91	4894	4.81	4821	4.71	4782	4.65	4700	4.53	4656	4.46	4561	4.32	4455	4.17	4189	3.78	3731	3.12				
	8437	97	8310	97	8196	97	8120	97	7981	97	7915	97	7745	96	7574	96	7121	95	6335	93				
1750	5354	6.01	5295	5.91	5232	5.81	5199	5.76	5131	5.64	5095	5.59	5019	5.46	4938	5.33	4751	5.01	4515	4.52	4167	4.06		
	9102	99	8991	99	8894	99	8828	99	8712	99	8662	99	8522	98	8395	98	8077	98	7666	97	7084	96		
1800	5546	6.60	5490	6.51	5431	6.41	5401	6.36	5337	6.25	5304	6.19	5235	6.07	5162	5.94	4997	5.65	4798	5.30	4540	4.85	3942	3.85
	9428	100	9322	100	9233	100	9171	100	9062	99	9017	99	8889	99	8775	99	8495	99	8147	98	7718	98	6694	96

Condiciones Estándar: 0 m.s.n.m. y 20 °C



Los valores de caudal y presión están certificados para instalación tipo B: Sin ducto en la succión y ducto en la descarga. Estos valores no incluyen los efectos de accesorios. Los valores de potencia (BHP) no incluyen las pérdidas por transmisión.

Performance certified is for installation type B: free inlet, ducted outlet. Performance ratings does not include the effects of appurtenances (accessories). Power ratings (kW/BHP) does not include transmission losses.

CURVA CARACTERÍSTICA DA 10/10

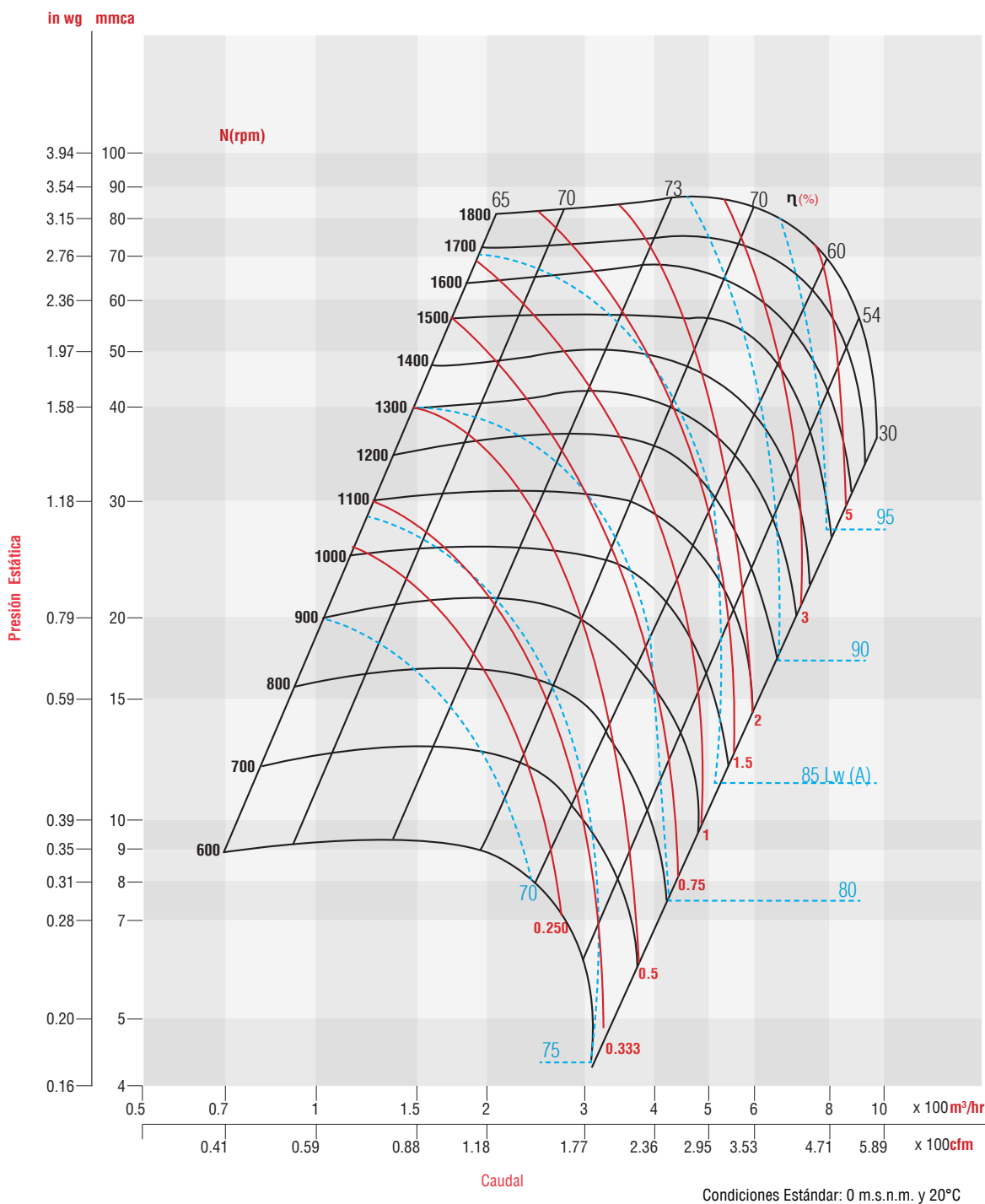

Condiciones Estándar: 0 m.s.n.m. y 20°C



Los valores de caudal y presión están certificados para instalación tipo B: Sin ducto en la succión y ducto en la descarga. Estos valores no incluyen los efectos de accesorios. Los valores de potencia (BHP) no incluyen las pérdidas por transmisión.

Performance certified is for installation type B: free inlet, ducted outlet. Performance ratings does not include the effects of appurtenances (accessories). Power ratings (kW/BHP) does not include transmission losses.

CARACTERÍSTICAS PRINCIPALES DA 12/12

DA 12/12

RPM	PRESIÓN ESTÁTICA mmca/ inwg																							
	6.35mm / 0.250"		8.890mm / 0.350"		9.525mm / 0.375"		10.160mm / 0.400"		11.430mm / 0.450"		12.700mm / 0.500"		13.970mm / 0.550"		15.240mm / 0.600"		15.875mm / 0.625"		17.780mm / 0.700"		19.050mm / 0.750"		25.400mm / 1.000"	
	CFM	BHP	CFM	BHP	CFM	BHP	CFM	BHP	CFM	BHP	CFM	BHP	CFM	BHP	CFM	BHP	CFM	BHP	CFM	BHP	CFM	BHP	CFM	BHP
	m³/hr	dB (A)	m³/hr	dB (A)	m³/hr	dB (A)	m³/hr	dB (A)	m³/hr	dB (A)	m³/hr	dB (A)	m³/hr	dB (A)	m³/hr	dB (A)	m³/hr	dB (A)	m³/hr	dB (A)	m³/hr	dB (A)	m³/hr	dB (A)
500	2183	0.32	477	0.08	322	0.07	212	0.06																
	3709	73	810	55	547	51	360	46																
550	2610	0.49	2127	0.36	1878	0.30	764	0.13	372	0.1														
	4434	76	3614	74	3191	72	1298	62	632	54														
600	2988	0.68	2661	0.57	2553	0.53	2424	0.49	1997	0.37	600	0.14	346	0.12										
	5077	78	4521	77	4338	77	4118	76	3393	74	1019	60	588	54										
650	3342	0.91	3082	0.80	3005	0.77	2921	0.74	2722	0.66	2438	0.56	1060	0.23	572	0.17	454	0.16	209	0.13				
	5678	81	5236	80	5105	79	4963	79	4625	78	4142	77	1801	67	972	60	771	58	355	49				
700	3682	1.18	3463	1.07	3401	1.04	3335	1.01	3191	0.94	3019	0.86	2801	0.77	2466	0.64	2109	0.52	596	0.21	399	0.19		
	6256	82	5884	82	5778	82	5666	81	5422	81	5129	80	4759	79	4190	78	3583	76	1013	61	678	57		
750	4013	1.49	3821	1.38	3769	1.35	3714	1.32	3597	1.25	3466	1.18	3316	1.10	3137	1.01	3031	0.96	2533	0.74	975	0.32		
	6818	84	6492	84	6404	83	6310	83	6111	83	5889	82	5634	82	5330	81	5150	81	4304	79	1657	68		
800	4337	1.84	4166	1.73	4120	1.70	4072	1.67	3972	1.6	3864	1.54	3745	1.46	3612	1.38	3539	1.34	3279	1.19	3043	1.07	400	0.27
	7369	86	7078	85	7000	85	6918	85	6748	85	6565	84	6363	84	6137	84	6013	83	5571	82	5170	82	680	58
850	4657	2.25	4501	2.13	4460	2.1	4418	2.07	4330	2.00	4236	1.93	4136	1.86	4027	1.79	3969	1.75	3776	1.62	3625	1.52	867	0.41
	7912	87	7647	87	7578	87	7506	87	7357	86	7197	86	7027	86	6842	85	6743	85	6415	85	6159	84	1473	68
875	4815	2.47	4667	2.35	4627	2.32	4587	2.29	4504	2.22	4416	2.15	4322	2.08	4222	2.01	4169	1.97	3996	1.84	3865	1.75	1369	0.56
	8181	88	7929	87	7861	87	7793	87	7652	87	7503	87	7343	87	7173	86	7083	86	6789	86	6567	85	2326	73
900	4973	2.70	4830	2.58	4793	2.55	4754	2.52	4675	2.45	4592	2.38	4504	2.31	4411	2.24	4362	2.20	4204	2.08	4087	1.99	3108	1.32
	8449	88	8206	88	8143	88	8077	88	7943	88	7802	88	7652	87	7494	87	7411	87	7143	87	6944	86	5280	83

RPM	PRESIÓN ESTÁTICA mmca/ inwg																							
	28.575mm / 1.125"		31.750mm / 1.250"		34.925mm / 1.375"		35.560mm / 1.400"		38.100mm / 1.500"		41.275mm / 1.625"		43.180mm / 1.700"		44.450mm / 1.750"		47.625mm / 1.875"		50.800mm / 2.000"		53.975mm / 2.125"		63.500mm / 2.500"	
	CFM	BHP	CFM	BHP	CFM	BHP	CFM	BHP	CFM	BHP	CFM	BHP	CFM	BHP	CFM	BHP	CFM	BHP	CFM	BHP	CFM	BHP	CFM	BHP
	m³/hr	dB (A)	m³/hr	dB (A)	m³/hr	dB (A)	m³/hr	dB (A)	m³/hr	dB (A)	m³/hr	dB (A)	m³/hr	dB (A)	m³/hr	dB (A)	m³/hr	dB (A)	m³/hr	dB (A)	m³/hr	dB (A)	m³/hr	dB (A)
950	3191	1.5	965	0.57	557	0.48	498	0.46	296	0.42														
	5422	84	1640	70	946	64	846	63	503	57														
1000	3992	2.24	3329	1.73	1061	0.68	954	0.65	644	0.57	377	0.5	249	0.47	173	0.45								
	6782	87	5656	85	1803	72	1621	71	1094	66	641	60	423	55	294	51								
1050	4529	2.91	4157	2.56	3521	2.02	3260	1.83	1859	0.81	749	0.68	572	0.63	472	0.6	261	0.55						
	7595	89	7053	88	5982	86	5539	85	2020	79	1273	68	972	65	802	63	443	56						
1100	4986	3.61	4707	3.31	4345	2.93	4255	2.84	3757	2.38	1358	0.97	1029	0.86	873	0.81	581	0.72	360	0.65	180	0.6		
	8471	91	7997	90	7382	89	7229	89	6383	87	2307	76	1748	72	1483	71	987	66	612	60	306	52		
1150	5403	4.37	5173	4.08	4900	3.75	4838	3.68	4552	3.36	4019	2.81	3148	2.06	1588	1.17	1021	0.96	706	0.85	473	0.78		
	9180	92	8789	92	8325	91	8220	91	7734	90	6828	89	5348	86	2698	78	1735	73	1199	69	804	64		
1200	5796	5.18	5597	4.91	5371	4.6	5322	4.54	5106	4.26	4775	3.85	4517	3.55	4297	3.3	1950	1.47	1199	1.14	850	1.01	232	0.79
	9847	93	9509	93	9125	92	9042	92	8675	92	8113	91	7674	90	7301	90	3313	81	2037	75	1444	71	394	56
1250	6171	6.06	5994	5.79	5799	5.5	5758	5.44	5580	5.18	5325	4.82	5146	4.58	5012	4.4	4584	3.86	3647	2.86	1419	1.36	530	1
	10485	94	10184	94	9853	94	9783	94	9480	93	9047	93	8743	92	8515	92	7788	91	6196	88	2411	77	900	66
1300	6534	7.02	6374	6.75	6201	6.46	6164	6.40	6011	6.15	5798	5.82	5656	5.60	5554	5.44	5260	5.01	4876	4.49	4234	3.69	908	1.28
	11101	95	10829	95	10535	95	10473	95	10213	94	9851	94	9610	94	9436	94	8937	93	8284	92	7194	90	1543	73
1350	6888	8.04	6741	7.78	6585	7.49	6552	7.44	6415	7.19	6231	6.87	6110	6.67	6025	6.52	5792	6.14	5517	5.7	5171	5.18	1453	1.68
	11703	96	11453	96	11188	96	11132	96	10899	96	10586	95	10381	95	10236	95	9841	94	9373	94	8786	93	2469	78
1400	7235	9.15	7099	8.88	6955	8.6	6925	8.54	6802	8.31	6637	7.99	6531	7.79	6458	7.66	6260	7.3	6038	6.9	5781	6.46	4218	4.17
	12992	97	12061	97	11817	97	11766	97	11557	97	11276	96	11096	96	10972	96	10636	96	10259	95	9822	95	7166	91

Condiciones Estándar: 0 m.s.n.m. y 20 °C



Los valores de caudal y presión están certificados para instalación tipo B: Sin ducto en la succión y ducto en la descarga. Estos valores no incluyen los efectos de accesorios. Los valores de potencia (BHP) no incluyen las pérdidas por transmisión.

Performance certified is for installation type B: free inlet, ducted outlet. Performance ratings does not include the effects of appurtenances (accessories). Power ratings (kW/BHP) does not include transmission losses.

CURVA CARACTERÍSTICA DA 12/12

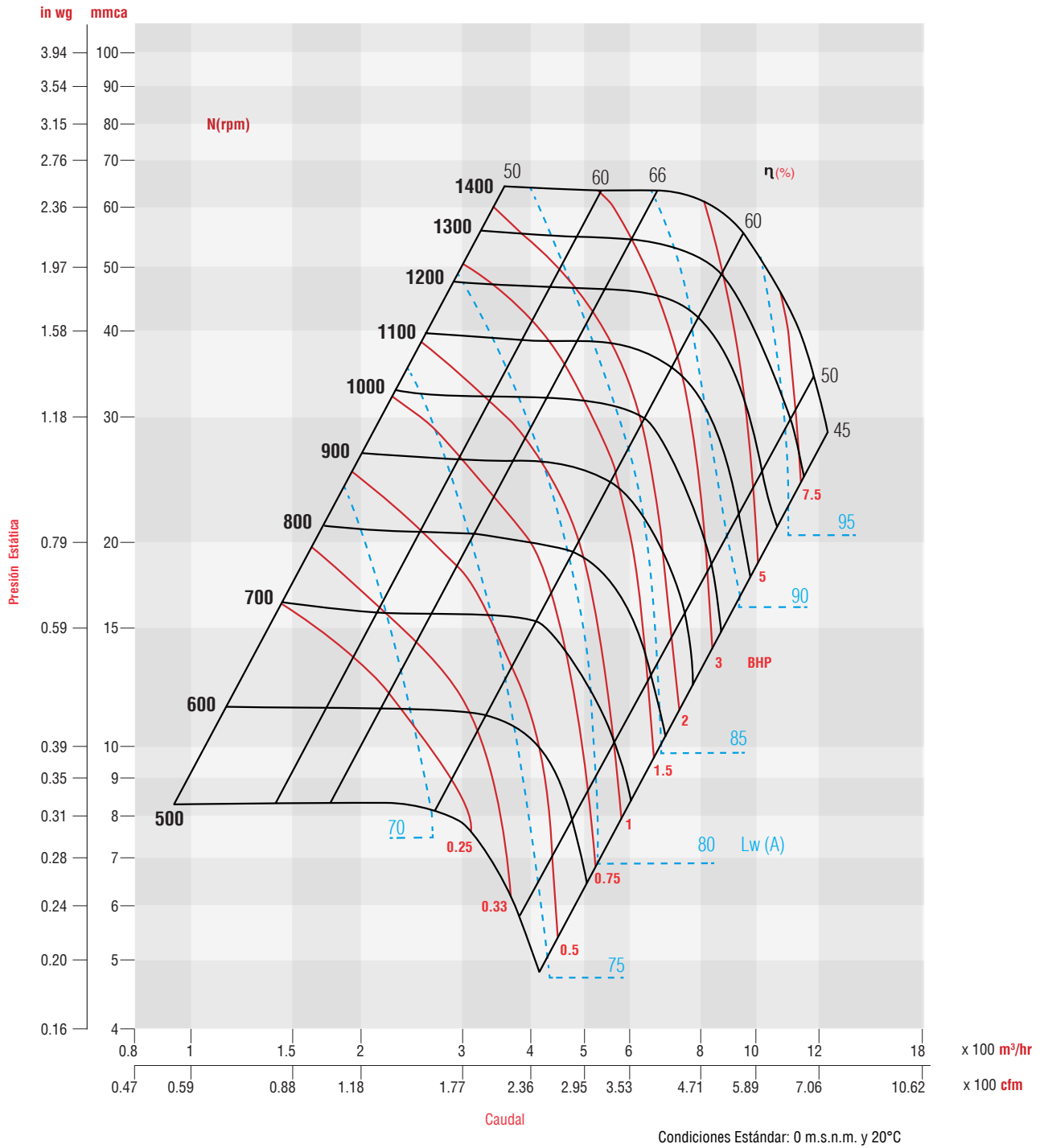

Los valores de caudal y presión están certificados para instalación tipo B: Sin ducto en la succión y ducto en la descarga. Estos valores no incluyen los efectos de accesorios. Los valores de potencia (BHP) no incluyen las pérdidas por transmisión.

Performance certified is for installation type B: free inlet, ducted outlet. Performance ratings does not include the effects of appurtenances (accessories). Power ratings (kW/BHP) does not include transmission losses.

CARACTERÍSTICAS PRINCIPALES DA 15/15

DA 15/15

RPM	PRESIÓN ESTÁTICA mmca / inwg																							
	6.35 mm / 0.250"		7.93 mm / 0.312"		9.53 mm / 0.375"		11.11 mm / 0.437"		12.70 mm / 0.500"		14.28 mm / 0.562"		15.87 mm / 0.625"		19.05 mm / 0.750"		20.63 mm / 0.812"		23.81 mm / 0.937"		25.40 mm / 1.000"		28.57 mm / 1.125"	
	CFM	BHP	CFM	BHP	CFM	BHP	CFM	BHP	CFM	BHP	CFM	BHP	CFM	BHP	CFM	BHP	CFM	BHP	CFM	BHP	CFM	BHP	CFM	BHP
	m³/hr	dB (A)	m³/hr	dB (A)	m³/hr	dB (A)	m³/hr	dB (A)	m³/hr	dB (A)	m³/hr	dB (A)	m³/hr	dB (A)	m³/hr	dB (A)	m³/hr	dB (A)	m³/hr	dB (A)	m³/hr	dB (A)	m³/hr	dB (A)
400	3459	0.40	3180	0.35																				
	5880	70	5400	69																				
425	3776	0.50	3566	0.45	3231	0.38																		
	6412	72	6055	72	5486	69																		
475	4370	0.74	4221	0.70	4037	0.65	3786	0.58	3308	0.46														
	7420	75	7167	75	6855	74	6429	73	5617	70														
525	4934	1.04	4816	1.00	4680	0.95	4520	0.89	4324	0.83	4046	0.74												
	8378	78	8178	78	7947	77	7675	77	7342	75	6870	75												
575	5483	1.40	5384	1.36	5274	1.31	5151	1.26	5013	1.20	4849	1.13	4648	1.05										
	9310	80	9142	81	8955	80	8746	80	8512	79	8234	79	7892	78										
625	6021	1.84	5936	1.79	5842	1.74	5741	1.69	5631	1.63	5508	1.57	5371	1.50	5012	1.34	4742	1.22						
	10236	82	10079	83	9931	82	9748	82	9573	81	9353	82	9120	81	8520	79	8052	79						
675	6554	2.35	6478	2.30	6396	2.25	6309	2.19	6217	2.14	6116	2.08	6008	2.01	5753	1.87	5597	1.78	5169	1.56	4795	1.38		
	11142	84	11000	85	10873	84	10713	84	10569	83	10385	84	10202	84	9780	82	9504	83	8777	81	8152	78		
725	7081	2.94	7013	2.89	6940	2.83	6863	2.78	6783	2.72	6697	2.66	6607	2.60	6403	2.46	6286	2.38	6011	2.21	5841	2.10	5629	1.98
	12038	86	11908	86	11798	86	11653	86	11531	85	11372	86	11219	86	10885	84	10674	85	10207	84	9930	82	9558	82
775	7606	3.62	7543	3.56	7477	3.51	7408	3.45	7337	3.39	7261	3.33	7183	3.27	7011	3.13	6915	3.06	6703	2.90	6583	2.81	6446	2.71
	12930	87	12808	88	12711	87	12579	88	12473	87	12329	88	12197	88	11919	86	11742	87	11382	87	11191	85	10945	84
790	7762	3.84	7701	3.79	7637	3.73	7570	3.67	7501	3.61	7428	3.55	7353	3.49	7188	3.35	7097	3.28	6898	3.12	6786	3.03	6661	2.94
	13180	89	13076	89	12968	88	12854	88	12737	88	12613	88	12485	88	12205	88	12051	88	11713	87	11523	87	11310	85

RPM	PRESIÓN ESTÁTICA mmca / inwg																							
	31.75 mm / 1.250"		34.92 mm / 1.375"		38.10 mm / 1.500"		41.27 mm / 1.625"		47.62 mm / 1.875"		50.80 mm / 2.000"		53.97 mm / 2.125"		57.15 mm / 2.250"		60.32 mm / 2.375"		63.50 mm / 2.500"		69.85 mm / 2.750"		79.38 mm / 3.125"	
	CFM	BHP	CFM	BHP	CFM	BHP	CFM	BHP	CFM	BHP	CFM	BHP	CFM	BHP	CFM	BHP	CFM	BHP	CFM	BHP	CFM	BHP	CFM	BHP
	m³/hr	dB (A)	m³/hr	dB (A)	m³/hr	dB (A)	m³/hr	dB (A)	m³/hr	dB (A)	m³/hr	dB (A)	m³/hr	dB (A)	m³/hr	dB (A)	m³/hr	dB (A)	m³/hr	dB (A)	m³/hr	dB (A)	m³/hr	dB (A)
800	6354	2.76	5868	2.41																				
	10802	84	9964	83																				
825	6759	3.19	6411	2.91	5815	2.48																		
	11490	86	10886	85	9886	83																		
875	7476	4.09	7236	3.86	6937	3.60	6511	3.23																
	12709	88	12287	87	11793	86	11056	85																
925	8128	5.07	7939	4.86	7721	4.64	7459	4.37	6589	3.56														
	13818	90	13480	89	13126	89	12665	88	11188	86														
975	8745	6.15	8586	5.96	8410	5.75	8211	5.51	7698	4.94	7322	4.54	6631	3.87										
	14867	91	14579	91	14297	91	13942	90	13071	89	12447	88	11259	86										
1025	9340	7.34	9201	7.15	9051	6.95	8887	6.74	8498	6.24	8256	5.94	7958	5.58	7548	5.11	6487	4.01						
	15878	93	15623	92	15387	92	15090	92	14430	91	14035	91	13513	90	12832	89	11015	86						
1075	9918	8.66	9795	8.47	9664	8.27	9522	8.06	9201	7.60	9015	7.34	8802	7.04	8553	6.71	8244	6.31	7813	5.77				
	16861	94	16632	94	16429	94	16168	93	15623	93	15326	93	14946	92	14540	92	13998	91	13282	90				
1125	10486	10.1	10374	9.92	10256	9.72	10132	9.51	9855	9.07	9700	8.82	9530	8.56	9341	8.27	9126	7.95	8874	7.58	8125	6.55		
	17805	95	17615	95	17415	95	17204	95	16734	94	16471	94	16182	94	15861	94	15496	93	15068	93	13796	91		
1175	11044	11.7	10942	11.5	10835	11.3	10723	11.1	10478	10.7	10344	10.4	10200	10.2	10045	9.90	9874	9.62	9685	9.30	9219	8.56		
	18753	96	18580	96	18398	96	18208	96	17792	96	17564	96	17320	95	17056	95	16766	95	16445	95	15654	94		
1200	11321	12.5	11223	12.3	11120	12.1	11013	11.9	10782	11.5	10656	11.3	10522	11.0	10378	10.8	10222	10.5	10052	10.2	9649	9.5	8682	7.97
	19246	97	19057	97	18904	97	18700	96	18308	96	18115	96	17866	96	17643	96	17357	96	17088	96	16403	95	14742	94

Condiciones Estándar: 0 m.s.n.m. y 20 °C



Los valores de caudal y presión están certificados para instalación tipo B: Sin ducto en la succión y ducto en la descarga. Estos valores no incluyen los efectos de accesorios. Los valores de potencia (BHP) no incluyen las pérdidas por transmisión.

Performance certified is for installation type B: free inlet, ducted outlet. Performance ratings does not include the effects of appurtenances (accessories). Power ratings (kW/BHP) does not include transmission losses.

CURVA CARACTERÍSTICA DA 15/15

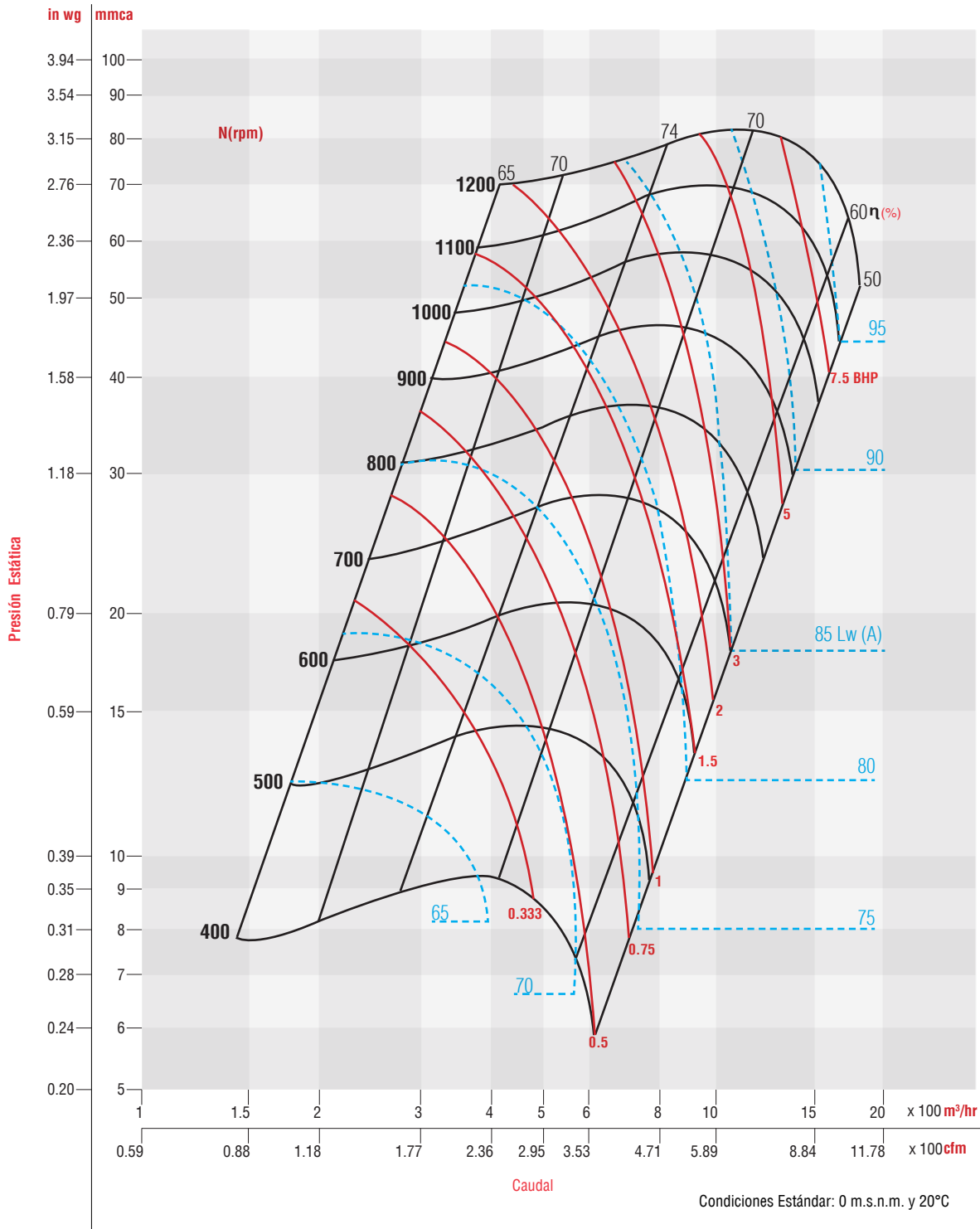

Los valores de caudal y presión están certificados para instalación tipo B: Sin ducto en la succión y ducto en la descarga. Estos valores no incluyen los efectos de accesorios. Los valores de potencia (BHP) no incluyen las pérdidas por transmisión.

Performance certified is for installation type B: free inlet, ducted outlet. Performance ratings does not include the effects of appurtenances (accessories). Power ratings (kW/BHP) does not include transmission losses.

CARACTERÍSTICAS PRINCIPALES DA 18/18

DA 18/18

RPM	PRESIÓN ESTÁTICA mmca / inwg																							
	4.76 mm / 0.188"		6.35 mm / 0.250"		7.93 mm / 0.313"		9.53 mm / 0.375"		11.11 mm / 0.437"		12.70 mm / 0.500"		14.28 mm / 0.562"		17.46 mm / 0.687"		19.05 mm / 0.750"		22.22 mm / 0.875"		25.40 mm / 1.000"		28.57 mm / 1.125"	
	CFM m³/hr	BHP dB (A)	CFM m³/hr	BHP dB (A)	CFM m³/hr	BHP dB (A)	CFM m³/hr	BHP dB (A)	CFM m³/hr	BHP dB (A)	CFM m³/hr	BHP dB (A)	CFM m³/hr	BHP dB (A)	CFM m³/hr	BHP dB (A)	CFM m³/hr	BHP dB (A)	CFM m³/hr	BHP dB (A)	CFM m³/hr	BHP dB (A)	CFM m³/hr	BHP dB (A)
300	4187	0.37	3426	0.26																				
	7110	73	5824	68																				
325	4811	0.52	4257	0.41	3284	0.27																		
	8169	76	7237	73	5576	67																		
375	5971	0.91	5554	0.80	5081	0.68	4484	0.54																
	10139	80	9442	79	8628	77	7623	74																
425	7077	1.45	6718	1.31	6344	1.18	5948	1.04	5483	0.90	4875	0.73												
	12017	84	11421	83	10772	82	10112	80	9310	79	8288	76												
475	8156	2.14	7830	1.98	7504	1.83	7177	1.68	6827	1.53	6450	1.38	6008	1.22										
	13849	87	13311	86	12742	85	12201	85	11592	83	10965	82	10202	81										
525	9219	3.02	8916	2.83	8619	2.66	8329	2.49	8030	2.32	7725	2.16	7397	1.99	6639	1.64	6146	1.43						
	15654	90	15157	89	14635	88	14159	88	13635	87	13133	86	12560	85	11273	83	10448	81						
575	10271	4.11	9986	3.89	9709	3.68	9442	3.49	9173	3.30	8905	3.12	8628	2.94	8039	2.58	7715	2.40	6927	1.98	5253	1.25		
	17440	92	16976	92	16486	91	16051	90	15576	90	15139	89	14650	88	13650	87	13116	86	11762	84	8930	78		
620	11212	5.28	10939	5.03	10675	4.79	10424	4.58	10173	4.37	9927	4.17	9676	3.97	9162	3.59	8894	3.39	8303	3.00	7586	2.55	6477	1.95
	19038	94	18596	94	18126	93	17721	93	17274	92	16876	92	16430	91	15557	90	15120	89	14098	88	12896	86	10998	82
660	12044	6.48	11780	6.20	11526	5.94	11286	5.71	11047	5.48	10816	5.26	10581	5.04	10111	4.63	9371	4.42	9362	4.10	8798	3.58	8126	3.11
	20451	96	20026	95	19571	95	19186	94	18758	94	18387	93	17967	93	17168	92	15931	90	15897	90	14957	89	13798	87
680	12458	7.14	12199	6.85	11949	6.58	11714	6.33	11480	6.09	11255	5.86	11027	5.64	10573	5.20	10344	4.99	9864	4.57	9344	4.14	8753	3.68
	21154	96	20738	96	20289	96	19914	95	19493	95	19134	94	18724	94	17953	93	17585	92	16749	91	15885	90	14863	89

RPM	PRESIÓN ESTÁTICA mmca / inwg																							
	31.75 mm / 1.250"		34.92 mm / 1.375"		38.10 mm / 1.500"		41.27 mm / 1.625"		44.45 mm / 1.750"		47.62 mm / 1.875"		50.8 mm / 2.000"		57.15 mm / 2.250"		63.50 mm / 2.500"		66.67 mm / 2.620"		69.85 mm / 2.750"		76.20 mm / 3.000"	
	CFM m³/hr	BHP dB (A)	CFM m³/hr	BHP dB (A)	CFM m³/hr	BHP dB (A)	CFM m³/hr	BHP dB (A)	CFM m³/hr	BHP dB (A)	CFM m³/hr	BHP dB (A)	CFM m³/hr	BHP dB (A)	CFM m³/hr	BHP dB (A)	CFM m³/hr	BHP dB (A)	CFM m³/hr	BHP dB (A)	CFM m³/hr	BHP dB (A)	CFM m³/hr	BHP dB (A)
700	8706	3.78	7884	3.18																				
	14783	89	13387	87																				
720	9322	4.42	8655	3.87	7708	3.18																		
	15829	90	14696	89	13104	86																		
760	10440	5.78	9920	5.27	9313	4.71	8529	4.05	6797	2.80														
	17727	93	16844	92	15832	90	14482	88	11555	83														
800	11472	7.29	11027	6.78	10540	6.25	9987	5.68	9313	5.03	8337	4.17												
	19479	95	18724	94	17918	93	16958	92	15832	90	14156	88												
840	12454	8.97	12056	8.45	11634	7.92	11178	7.36	10671	6.78	10080	6.13	9322	5.36										
	21147	96	20471	96	19778	95	18980	94	18141	93	17116	92	15847	90										
880	13403	10.9	13038	10.3	12658	9.75	12259	9.20	11831	8.62	11364	8.02	10835	7.38	9342	5.73								
	22758	98	22139	97	21519	97	20816	96	20113	95	19296	94	18420	93	15881	90								
920	14330	12.9	13988	12.4	13638	11.8	13276	11.2	12897	10.6	12496	10.0	12063	9.42	11035	8.05	9385	6.13						
	24332	100	23752	99	23185	98	22543	98	21925	97	21218	97	20507	96	18760	94	15955	90						
960	15240	15.2	14917	14.6	14589	14.0	14254	13.4	13908	12.8	13549	12.2	13170	11.6	12329	10.3	11277	8.82	10571	7.90	9473	6.60		
	25878	101	25329	100	24801	100	24203	99	23644	99	23006	98	22389	98	20959	96	19171	94	17950	93	16104	91		
990	15913	17.1	15602	16.5	15288	15.9	14968	15.2	14642	14.6	14305	14.0	13955	13.4	13198	12.1	12314	10.7	11787	9.90	11153	9.01		
	27020	102	26492	101	25959	101	25416	100	24862	100	24290	99	23696	99	22410	98	20909	96	20014	95	18938	94		
1000	16136	17.8	15829	17.1	15518	16.5	15204	15.9	14882	15.3	14552	14.6	14210	14.0	13475	12.7	12631	11.3	12138	10.6	11564	9.71	9644	7.19
	27399	102	26878	102	26381	101	25816	101	25299	100	24709	100	24157	99	22908	98	21473	97	20610	96	19659	95	16376	91

Condiciones Estándar: 0 m.s.n.m. y 20 °C



Los valores de caudal y presión están certificados para instalación tipo B: Sin ducto en la succión y ducto en la descarga. Estos valores no incluyen los efectos de accesorios. Los valores de potencia (BHP) no incluyen las pérdidas por transmisión.

Performance certified is for installation type B: free inlet, ducted outlet. Performance ratings does not include the effects of appurtenances (accessories). Power ratings (kW/BHP) does not include transmission losses.

CURVA CARACTERÍSTICA DA 18/18

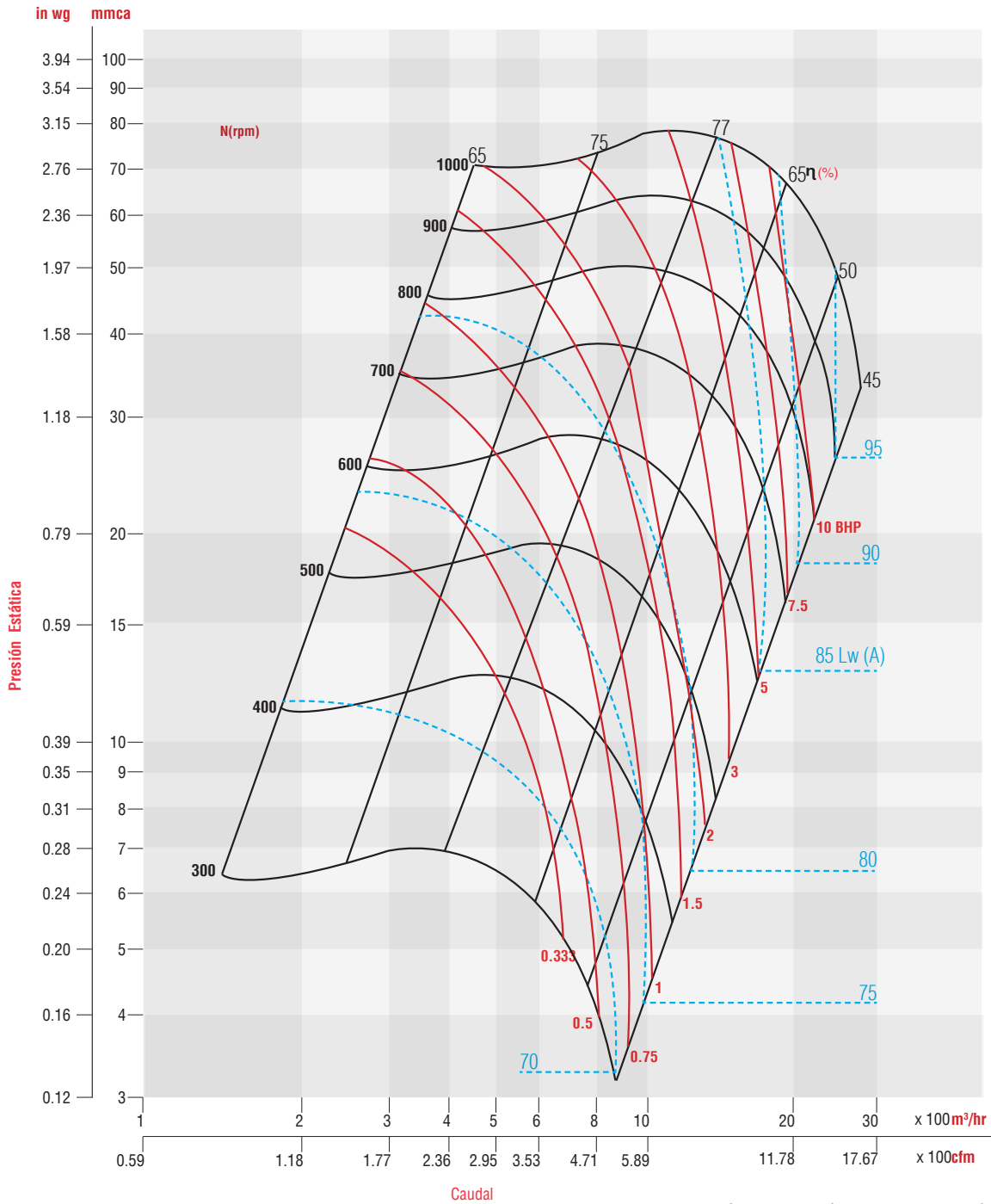

Condiciones Estándar: 0 m.s.n.m. y 20°C



Los valores de caudal y presión están certificados para instalación tipo B: Sin ducto en la succión y ducto en la descarga. Estos valores no incluyen los efectos de accesorios. Los valores de potencia (BHP) no incluyen las pérdidas por transmisión.

Performance certified is for installation type B: free inlet, ducted outlet. Performance ratings does not include the effects of appurtenances (accessories). Power ratings (kW/BHP) does not include transmission losses.

CARACTERÍSTICAS PRINCIPALES DA 20/20

DA 20/20

RPM	PRESIÓN ESTÁTICA mmca / inwg																							
	4.76 mm / 0.187"		6.35 mm / 0.250"		7.93 mm / 0.312"		9.525 mm / 0.375"		11.11 mm / 0.437"		12.70 mm / 0.500"		15.88 mm / 0.625"		19.05 mm / 0.750"		22.22 mm / 0.875"		25.40 mm / 1.000"		31.75 mm / 1.250"		38.10 mm / 1.500"	
	CFM	BHP	CFM	BHP	CFM	BHP	CFM	BHP	CFM	BHP	CFM	BHP	CFM	BHP	CFM	BHP	CFM	BHP	CFM	BHP	CFM	BHP	CFM	BHP
	m³/hr	dB (A)	m³/hr	dB (A)	m³/hr	dB (A)	m³/hr	dB (A)	m³/hr	dB (A)	m³/hr	dB (A)	m³/hr	dB (A)	m³/hr	dB (A)	m³/hr	dB (A)	m³/hr	dB (A)	m³/hr	dB (A)	m³/hr	dB (A)
300	5426	0.58	4738	0.46	3676	0.32																		
	9213	71	8055	68	6242	62																		
325	6176	0.81	5596	0.67	4894	0.54	3773	0.37																
	10487	74	9502	72	8310	69	6407	63																
375	7607	1.41	7128	1.24	6624	1.08	6076	0.93	5395	0.77	4335	0.57												
	12917	78	12103	77	11248	75	10317	73	9161	71	7361	66												
425	8990	2.25	8563	2.03	8134	1.83	7703	1.65	7237	1.48	6728	1.31	5261	0.91										
	15265	82	14540	81	13812	80	13080	78	12288	77	11424	76	8933	70										
475	10350	3.36	9953	3.08	9566	2.83	9189	2.61	8801	2.40	8405	2.21	7516	1.82	6311	1.40								
	17574	85	16900	84	16243	83	15603	82	14944	81	14272	80	12762	78	10716	74								
525	11695	4.78	11319	4.43	10958	4.13	10613	3.85	10267	3.60	9924	3.37	9205	2.93	8402	2.51	7401	2.06	5624	1.43				
	19858	88	19220	87	18607	86	18021	85	17433	85	16851	84	15630	82	14267	80	12567	78	9550	72				
575	13031	6.54	12670	6.12	12327	5.75	12004	5.42	11684	5.12	11372	4.84	10740	4.33	10080	3.85	9357	3.39	8508	2.91				
	22127	90	21514	89	20931	89	20383	88	19839	88	19310	87	18237	86	17116	84	15888	83	14447	81				
620	14227	8.45	13877	7.96	13547	7.52	13237	7.14	12934	6.79	12641	6.46	12059	5.87	11469	5.32	10854	4.81	10188	4.32	8492	3.26		
	24157	92	23563	91	23003	91	22476	90	21962	90	21464	89	20476	88	19474	87	18430	86	17320	85	14419	81		
660	15288	10.4	14945	9.87	14623	9.37	14324	8.94	14032	8.53	13752	8.17	13201	7.49	12653	6.88	12096	6.31	11514	5.77	10190	4.71	8253	3.46
	25959	93	25377	93	24830	92	24322	92	23826	92	23351	91	22415	90	21485	89	20539	88	19574	87	17303	85	14014	80
680	15817	11.5	15478	10.9	15160	10.4	14865	9.94	14577	9.51	14303	9.12	13764	8.40	13233	7.75	12698	7.15	12145	6.58	10927	5.49	9343	4.32
	26857	94	26282	94	25742	93	25241	93	24752	92	24286	92	23371	91	22470	90	21561	89	20647	88	18554	86	15864	83

RPM	PRESIÓN ESTÁTICA mmca / inwg																							
	41.27 mm / 1.620"		44.45 mm / 1.750"		47.62 mm / 1.875"		50.80 mm / 2.000"		57.15 mm / 2.250"		34.92 mm / 2.370"		63.50 mm / 2.500"		66.67 mm / 2.625"		69.85 mm / 2.750"		76.20 mm / 3.000"		82.55 mm / 3.250"		92.07 mm / 3.620"	
	CFM	BHP	CFM	BHP	CFM	BHP	CFM	BHP	CFM	BHP	CFM	BHP	CFM	BHP	CFM	BHP	CFM	BHP	CFM	BHP	CFM	BHP	CFM	BHP
	m³/hr	dB (A)	m³/hr	dB (A)	m³/hr	dB (A)	m³/hr	dB (A)	m³/hr	dB (A)	m³/hr	dB (A)	m³/hr	dB (A)	m³/hr	dB (A)	m³/hr	dB (A)	m³/hr	dB (A)	m³/hr	dB (A)	m³/hr	dB (A)
700	9333	4.51	7978	3.66																				
	15847	83	13547	79																				
720	10921	5.43	9337	4.73	7823	3.74																		
	18544	86	15854	83	13283	79																		
760	11900	7.35	11228	6.71	10433	6.02	9395	5.21																
	20206	88	19065	87	17715	85	15953	83																
800	13317	9.50	12764	8.84	12158	8.18	11471	7.49	9544	5.79	7110	4.04												
	22612	90	21673	89	20644	88	19478	87	16206	83	12073	77												
840	14634	11.9	14150	11.2	13637	10.5	13085	9.80	11782	8.39	10946	7.55	9811	6.52	7064	4.39								
	24849	92	24027	92	23156	91	22218	90	20006	88	18586	86	16659	84	11995	77								
880	15890	14.6	15451	13.8	14996	13.1	14517	12.4	13461	11.0	12855	10.3	12164	9.40	11332	8.50	10210	7.40						
	26981	94	26236	94	25463	93	24650	92	22857	91	21828	90	20654	88	19242	87	17337	85						
920	17104	17.6	16698	16.8	16281	16.0	15851	15.3	14933	13.8	14432	13.1	13891	12.3	13294	11.5	12615	10.7	10734	8.60	3627	2.90		
	29043	96	28353	95	27645	95	26915	94	25356	93	24506	92	23587	91	22573	90	21420	89	18226	86	6159	62		
960	18289	20.9	17907	20.1	17520	19.3	17123	18.5	16295	16.9	15856	16.2	15394	15.4	14902	14.6	14372	13.8	13131	12.1	11360	9.90		
	31055	97	30406	97	29749	96	29075	96	27669	95	26923	94	26139	94	25304	93	24404	92	22296	90	19289	87		
990	19163	23.7	18796	22.8	18425	21.9	18049	21.1	17270	19.5	16863	18.7	16441	17.9	15998	17.1	15530	16.3	14488	14.6	13202	12.8	9235	8.10
	32539	98	31916	98	31286	97	30647	97	29324	96	28633	95	27917	95	27165	94	26370	94	24601	92	22417	90	15681	82
1000	19452	24.6	19090	23.7	18724	22.9	18353	22.0	17589	20.4	17191	19.6	16779	18.8	16349	18.0	15898	17.2	14902	15.5	13707	13.7	10756	9.90
	33029	99	32415	98	31793	98	31163	97	29866	96	29190	96	28491	95	27761	95	26995	94	25304	93	23274	91	18264	86

Condiciones Estándar: 0 m.s.n.m. y 20 °C



Los valores de caudal y presión están certificados para instalación tipo B: Sin ducto en la succión y ducto en la descarga. Estos valores no incluyen los efectos de accesorios. Los valores de potencia (BHP) no incluyen las pérdidas por transmisión.

Performance certified is for installation type B: free inlet, ducted outlet. Performance ratings does not include the effects of appurtenances (accessories). Power ratings (kW/BHP) does not include transmission losses.

CURVA CARACTERÍSTICA DA 20/20

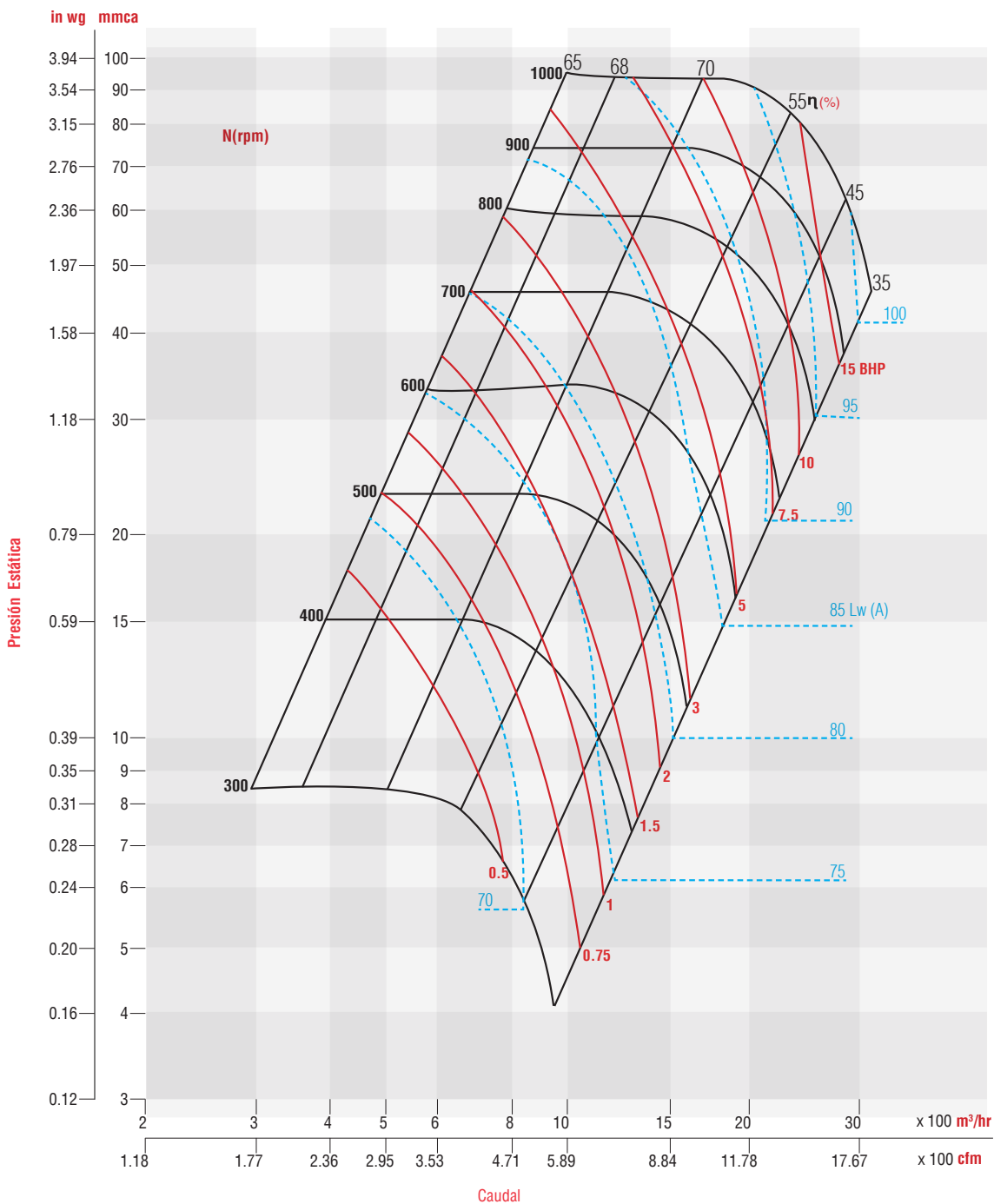

Los valores de caudal y presión están certificados para instalación tipo B: Sin ducto en la succión y ducto en la descarga. Estos valores no incluyen los efectos de accesorios. Los valores de potencia (BHP) no incluyen las pérdidas por transmisión.

Performance certified is for installation type B: free inlet, ducted outlet. Performance ratings does not include the effects of appurtenances (accessories). Power ratings (kW/BHP) does not include transmission losses.

CARACTERÍSTICAS PRINCIPALES DA 22/22

DA 22/22

RPM	PRESIÓN ESTÁTICA mmca / inwg																							
	6.35 mm / 0.250"		7.93 mm / 0.312"		9.53 mm / 0.375"		11.11 mm / 0.438"		12.70 mm / 0.500"		17.46 mm / 0.687"		19.05 mm / 0.750"		22.22 mm / 0.875"		25.40 mm / 1.000"		28.57 mm / 1.125"		31.75 mm / 1.250"		34.92 mm / 1.375"	
	CFM	BHP	CFM	BHP	CFM	BHP	CFM	BHP	CFM	BHP	CFM	BHP	CFM	BHP	CFM	BHP	CFM	BHP	CFM	BHP	CFM	BHP	CFM	BHP
	m³/hr	dB (A)	m³/hr	dB (A)	m³/hr	dB (A)	m³/hr	dB (A)	m³/hr	dB (A)	m³/hr	dB (A)	m³/hr	dB (A)	m³/hr	dB (A)	m³/hr	dB (A)	m³/hr	dB (A)	m³/hr	dB (A)	m³/hr	dB (A)
300	7749	1.02	6934	0.84	5820	0.64																		
	13173	73	11774	72	9894	68																		
320	8639	1.35	7939	1.15	7129	0.95	5931	0.72																
	14686	75	13480	74	12119	71	10071	71																
360	10332	2.18	9751	1.93	9149	1.71	8471	1.49	7666	1.26														
	17564	78	16557	78	15553	76	14384	76	13032	73														
400	11964	3.28	11445	2.97	10930	2.70	10389	2.44	9819	2.20	7334	1.39												
	20339	81	19434	80	18581	79	17641	79	16692	77	12453	75												
440	13562	4.67	13881	4.30	12617	3.98	12143	3.67	11666	3.39	10022	2.57	9332	2.29	6808	1.48								
	23055	83	23570	83	21449	82	20619	82	19832	80	17017	80	15864	78	11560	75								
480	15140	6.41	14685	5.96	14253	5.57	13821	5.21	13394	4.87	12035	3.95	11538	3.66	10373	3.07	8619	2.33						
	25738	85	24935	85	24230	84	23468	84	22770	83	20435	82	19615	81	17613	81	14652	78						
520	16703	8.52	16269	7.99	15859	7.53	15454	7.10	15061	6.71	13855	5.64	13439	5.32	12540	4.68	11495	4.04	10112	3.32				
	28395	87	27625	87	26960	86	26241	86	25604	85	23526	85	22846	84	21293	84	19542	82	17170	81				
550	17870	10.4	17446	9.80	17050	9.25	16661	8.77	16286	8.33	15157	7.15	14777	6.79	13980	6.10	13109	5.43	12102	4.75	10804	3.99	8134	2.72
	30343	89	29623	88	28951	88	28290	88	27654	87	25737	86	25091	86	23738	85	22259	84	20549	84	18345	83	13812	80
570	18645	11.7	18228	11.1	17840	10.53	17459	10.0	17024	9.54	16005	8.27	15212	7.32	14894	7.15	14095	6.45	13211	5.76	12170	5.04	10777	4.20
	31659	89	30951	89	30292	89	29645	88	28907	88	27176	87	25830	87	25290	86	23933	86	22432	85	20665	84	18299	83
580	19032	12.5	18618	11.8	18233	11.2	17856	10.7	17495	10.2	16425	8.90	16071	8.47	15341	7.72	14572	7.00	13732	6.29	12772	5.57	11569	4.78
	32354	90	31613	90	30996	89	30319	89	29742	88	27890	88	27321	87	26049	87	24772	86	23317	85	21687	85	19644	84

RPM	PRESIÓN ESTÁTICA mmca / inwg																							
	38.10 mm / 1.500"		39.68 mm / 1.565"		41.27 mm / 1.625"		44.45 mm / 1.750"		50.80 mm / 2.000"		55.57 mm / 2.187"		57.15 mm / 2.250"		63.50 mm / 2.500"		69.85 mm / 2.750"		73.02 mm / 2.875"		76.20 mm / 3.000"		85.72 mm / 3.375"	
	CFM	BHP	CFM	BHP	CFM	BHP	CFM	BHP	CFM	BHP	CFM	BHP	CFM	BHP	CFM	BHP	CFM	BHP	CFM	BHP	CFM	BHP	CFM	BHP
	m³/hr	dB (A)	m³/hr	dB (A)	m³/hr	dB (A)	m³/hr	dB (A)	m³/hr	dB (A)	m³/hr	dB (A)	m³/hr	dB (A)	m³/hr	dB (A)	m³/hr	dB (A)	m³/hr	dB (A)	m³/hr	dB (A)	m³/hr	dB (A)
600	11641	5.08	10765	4.55	9359	3.78																		
	19766	85	18279	84	15892	83																		
620	13054	6.34	12452	5.90	11745	5.42	9017	3.82																
	22166	87	21143	86	19943	86	15311	83																
660	15351	8.99	14930	8.58	14486	8.17	13456	7.28																
	26066	89	25351	89	24597	88	22848	88																
700	17354	12.0	17008	11.6	16654	11.2	15888	10.3	13988	8.43	11522	6.43												
	29467	91	28880	91	28278	91	26978	90	23752	89	19564	87												
740	19216	15.5	18911	15.0	18605	14.6	17962	13.7	16520	11.8	15184	10.4	14655	9.80	10324	6.18								
	32629	93	32111	93	31591	92	30499	92	28051	91	25782	90	24884	90	17530	86								
780	20993	19.4	20717	18.93	20441	18.4	19871	17.5	18649	15.6	17616	14.1	17242	13.6	15445	11.5	12061	8.21						
	35646	94	35177	94	34709	94	33741	94	31666	93	29912	92	29277	92	26226	91	20480	89						
820	22717	23.9	22460	23.4	22206	22.9	21684	21.8	20596	19.8	19715	18.3	19408	17.8	18047	15.7	16342	13.5	15209	12.2	13542	10.4		
	38573	99	38137	99	37706	99	36819	98	34972	98	33476	97	32955	96	30644	95	27749	94	25825	93	22994	91		
860	24402	29.0	24160	28.4	23921	27.8	23436	26.7	22438	24.5	21652	22.9	21383	22.4	20234	20.3	18927	18.2	18178	17.0	17326	15.8	12100	9.80
	41435	101	41024	100	40618	100	39794	100	38100	99	36765	98	36308	98	34357	97	32138	96	30866	95	29420	94	20546	89
890	25647	33.3	25414	32.6	25185	32.0	24720	30.8	23774	28.4	23038	26.8	22789	26.2	21741	24.0	20593	21.9	19963	20.8	19280	19.6	16619	15.7
	43549	102	43153	101	42764	101	41975	101	40368	100	39119	99	38696	99	36916	98	34967	97	33897	96	32737	95	28219	92
900	26059	34.8	25829	34.1	25602	33.5	25143	32.2	24212	29.8	23491	28.1	23247	27.6	22227	25.3	21119	23.2	20517	22.1	19871	20.9	17461	17.2
	44248	102	43858	102	43472	101	42693	101	41112	100	39888	100	39473	99	37741	98	35860	97	34838	97	33741	96	29649	93

Condiciones Estándar: 0 m.s.n.m. y 20 °C



Los valores de caudal y presión están certificados para instalación tipo B: Sin ducto en la succión y ducto en la descarga. Estos valores no incluyen los efectos de accesorios. Los valores de potencia (BHP) no incluyen las pérdidas por transmisión.

Performance certified is for installation type B: free inlet, ducted outlet. Performance ratings does not include the effects of appurtenances (accessories). Power ratings (kW/BHP) does not include transmission losses.

CURVA CARACTERÍSTICA DA 22/22

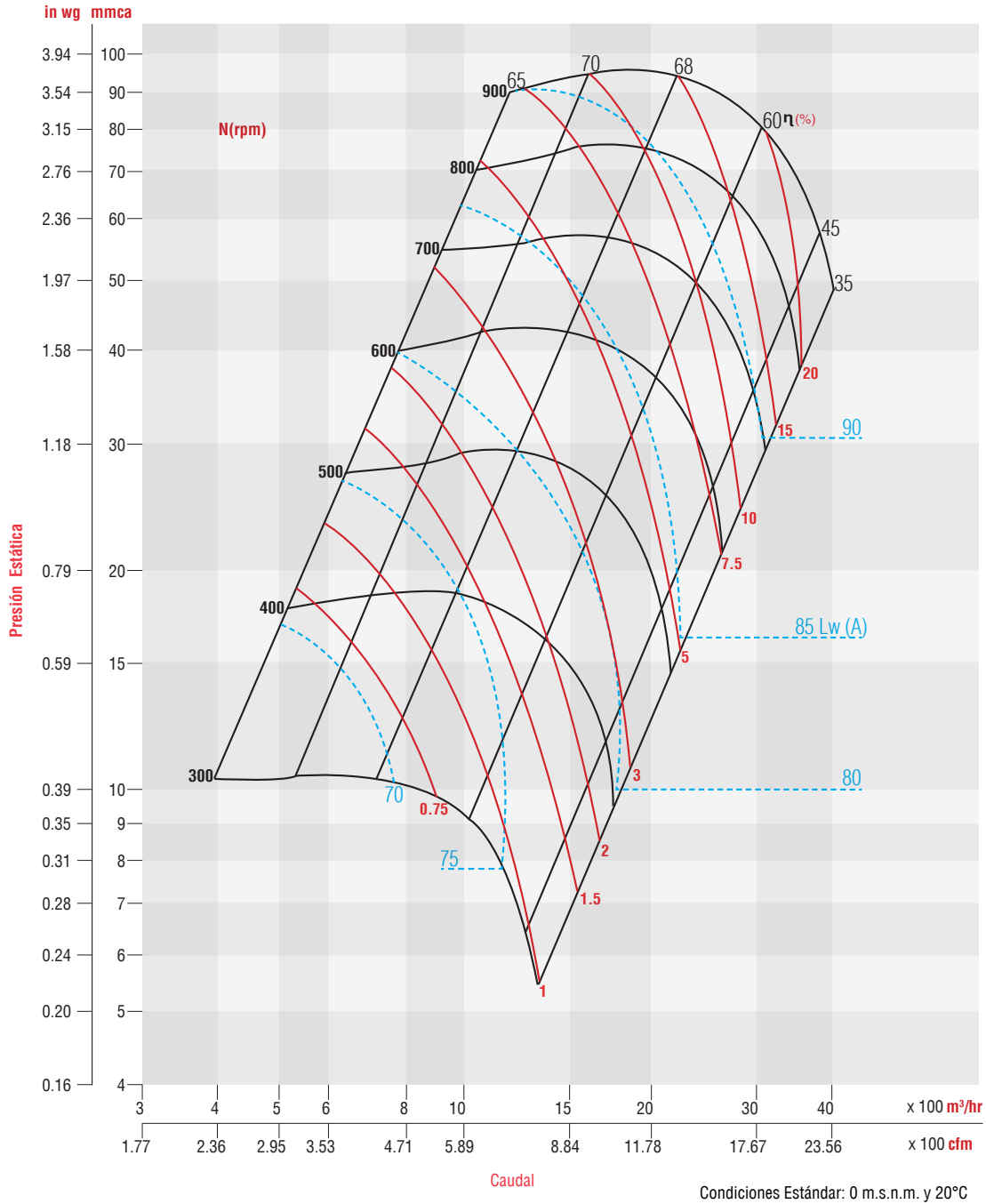

Los valores de caudal y presión están certificados para instalación tipo B: Sin ducto en la succión y ducto en la descarga. Estos valores no incluyen los efectos de accesorios. Los valores de potencia (BHP) no incluyen las pérdidas por transmisión.

Performance certified is for installation type B: free inlet, ducted outlet. Performance ratings does not include the effects of appurtenances (accessories). Power ratings (kW/BHP) does not include transmission losses.

CARACTERÍSTICAS PRINCIPALES DA 25/25

DA 25/25

RPM	PRESIÓN ESTÁTICA mmca / inwg																							
	6.35 mm / 0.250"		7.93 mm / 0.312"		9.53 mm / 0.375"		11.11 mm / 0.437"		12.70 mm / 0.500"		14.28 mm / 0.562"		15.87 mm / 0.625"		17.46 mm / 0.687"		19.05 mm / 0.750"		22.22 mm / 0.875"		25.40 mm / 1.000"		28.57 mm / 1.125"	
	CFM	BHP	CFM	BHP	CFM	BHP	CFM	BHP	CFM	BHP	CFM	BHP	CFM	BHP	CFM	BHP	CFM	BHP	CFM	BHP	CFM	BHP	CFM	BHP
	m³/hr	dB (A)	m³/hr	dB (A)	m³/hr	dB (A)	m³/hr	dB (A)	m³/hr	dB (A)	m³/hr	dB (A)	m³/hr	dB (A)	m³/hr	dB (A)	m³/hr	dB (A)	m³/hr	dB (A)	m³/hr	dB (A)	m³/hr	dB (A)
250	8687	0.97	7142	0.71																				
	14768	71	12127	70																				
260	9403	1.17	8131	0.92	5663	0.54																		
	15985	72	13806	72	9627	65																		
280	10739	1.62	9740	1.37	8473	1.09	5815	0.64																
	18256	74	16539	74	14404	70	9874	51																
300	11996	2.15	11142	1.88	10172	1.61	8900	1.3	6476	0.83														
	20393	76	18919	76	17292	74	15112	59	11009	67														
340	14383	3.48	13688	3.17	12963	2.87	12155	2.57	11241	2.25	10077	1.89	8273	1.41										
	24451	80	23242	80	22037	78	20639	68	19110	76	17111	65	14048	62										
370	16105	4.74	15483	4.39	14851	4.07	14175	3.74	13458	3.41	12649	3.06	11720	2.70	10516	2.28	8575	1.70						
	27379	82	26290	82	25247	81	24069	74	22879	79	21478	72	19901	70	17856	68	14578	74						
400	17791	6.24	17222	5.86	16653	5.50	16057	5.14	15445	4.79	14785	4.43	14080	4.07	13280	3.69	12362	3.28	9338	2.17				
	30245	84	29243	84	28310	83	27265	78	26257	82	25105	77	23908	76	22549	75	21015	79	15856	70				
430	19451	8.02	18924	7.60	18401	7.20	17862	6.8	17317	6.42	16743	6.04	16149	5.66	15507	5.27	14821	4.88	13161	4.02	10452	2.85		
	33028	86	32133	86	31245	85	30330	82	29404	84	28430	81	27421	81	26331	80	25166	81	22347	78	17747	76		
450	20547	9.36	20043	8.92	19545	8.49	19035	8.07	18524	7.67	17990	7.26	17446	6.87	16867	6.46	16264	6.06	14889	5.22	13106	4.26	9714	2.79
	34930	87	34033	87	33227	86	32321	85	31491	86	30547	84	29623	84	28640	83	27649	84	25282	81	22280	80	16494	76
470	21635	10.8	21151	10.37	20676	9.92	20191	9.47	19707	9.04	19206	8.62	18700	8.20	18168	7.78	17622	7.37	16420	6.52	14997	5.60	13085	4.53
	36780	88	35914	88	35149	88	34284	87	33502	87	32612	86	31753	86	30849	86	29957	85	27881	84	25495	83	22218	81

RPM	PRESIÓN ESTÁTICA mmca / inwg																							
	31.75 mm / 1.250"		34.92 mm / 1.375"		38.10 mm / 1.500"		42.84 mm / 1.687"		44.45 mm / 1.750"		50.80 mm / 2.000"		52.38 mm / 2.063"		60.32 mm / 2.375"		63.50 mm / 2.500"		69.85 mm / 2.750"		71.45 mm / 2.813"		79.37 mm / 3.125"	
	CFM	BHP	CFM	BHP	CFM	BHP	CFM	BHP	CFM	BHP	CFM	BHP	CFM	BHP	CFM	BHP	CFM	BHP	CFM	BHP	CFM	BHP	CFM	BHP
	m³/hr	dB (A)	m³/hr	dB (A)	m³/hr	dB (A)	m³/hr	dB (A)	m³/hr	dB (A)	m³/hr	dB (A)	m³/hr	dB (A)	m³/hr	dB (A)	m³/hr	dB (A)	m³/hr	dB (A)	m³/hr	dB (A)	m³/hr	dB (A)
500	14137	5.69	11389	4.11																				
	24005	85	19339	83																				
520	16286	7.37	14513	6.16	11326	4.35																		
	27654	87	24643	86	19254	81																		
550	18747	10.0	17488	8.93	15931	7.71	11523	4.90	6620	2.72														
	31832	89	29695	88	27083	86	19566	84	11254	75														
590	21621	14.0	20644	12.9	19559	11.8	17578	9.94	16761	9.24	7907	3.70												
	36712	91	35054	91	33250	89	29847	89	28494	86	13442	78												
620	23618	17.4	22758	16.3	21836	15.2	20272	13.4	19687	12.8	16609	9.82	15430	8.84										
	40103	93	38643	92	37121	91	34422	91	33468	89	28235	87	26200	88										
650	25532	21.2	24754	20.0	23936	18.9	22600	17.1	22122	16.5	19889	13.9	19205	13.1	12774	7.50								
	43353	94	42032	94	40691	93	38375	93	37607	92	33811	90	32610	91	21690	87								
690	27995	26.9	27295	25.7	26571	24.5	25423	22.6	25025	22.0	23274	19.4	22784	18.8	19822	15.0	18135	13.2						
	47536	96	46347	95	45171	95	43168	95	42543	94	39566	93	38687	94	33658	92	30830	90						
720	29794	31.7	29138	30.4	28466	29.1	27415	27.2	27054	26.6	25509	24.0	25090	23.3	22735	19.8	21589	18.3	18482	14.5	17306	13.2		
	50590	97	49476	97	48392	96	46551	96	45992	96	43365	95	42603	95	38604	94	36701	93	31419	91	29386	91		
740	30976	35.2	30345	33.9	29701	32.5	28701	30.6	28360	29.9	26916	27.3	26530	26.6	24419	23.1	23440	21.6	21055	18.3	20302	17.3	11335	8.30
	52597	98	51526	97	50492	97	48734	97	48212	97	45757	96	45048	96	41463	95	39848	95	35794	93	34473	93	19247	87
750	31562	37.0	30943	35.6	30312	34.3	29334	32.3	29002	31.6	27601	29.0	27228	28.3	25213	24.8	24295	23.3	22126	20.1	21470	19.2	16190	12.9
	53592	98	52541	98	51530	97	49809	97	49303	97	46922	97	46233	96	42812	96	41302	95	37614	94	36456	94	27491	91

Condiciones Estándar: 0 m.s.n.m. y 20 °C



Los valores de caudal y presión están certificados para instalación tipo B: Sin ducto en la succión y ducto en la descarga. Estos valores no incluyen los efectos de accesorios. Los valores de potencia (BHP) no incluyen las pérdidas por transmisión.

Performance certified is for installation type B: free inlet, ducted outlet. Performance ratings does not include the effects of appurtenances (accessories). Power ratings (kW/BHP) does not include transmission losses.

CURVA CARACTERÍSTICA DA 25/25

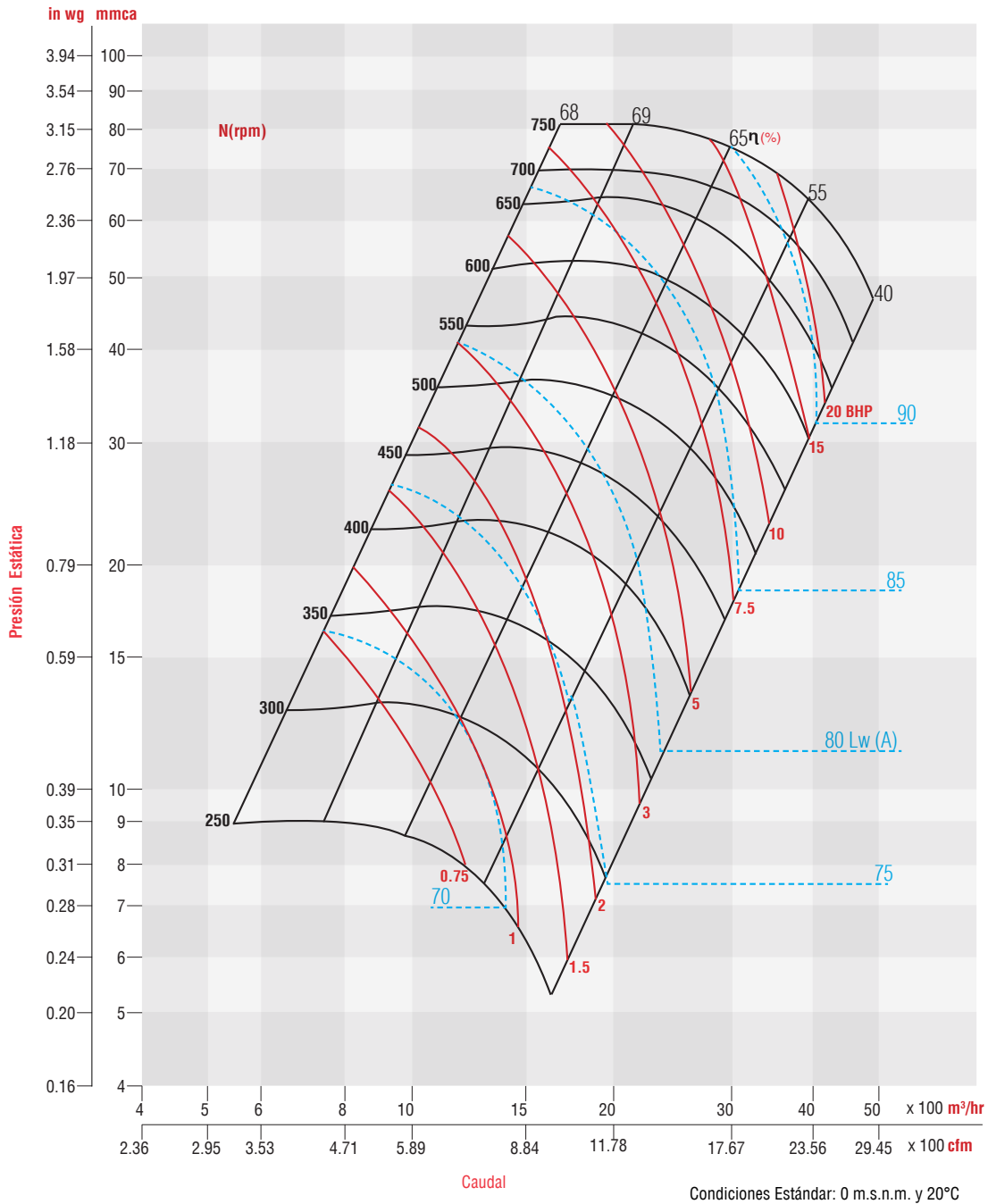

Los valores de caudal y presión están certificados para instalación tipo B: Sin ducto en la succión y ducto en la descarga. Estos valores no incluyen los efectos de accesorios. Los valores de potencia (BHP) no incluyen las pérdidas por transmisión.

Performance certified is for installation type B: free inlet, ducted outlet. Performance ratings does not include the effects of appurtenances (accessories). Power ratings (kW/BHP) does not include transmission losses.

CARACTERÍSTICAS PRINCIPALES DA 30/28

DA 22/22

		PRESIÓN ESTÁTICA mmca / inwg																										
		6.35 mm / 0.250"		7.93 mm / 0.312"		9.53 mm / 0.375"		12.70 mm / 0.500"		14.28 mm / 0.562"		15.87 mm / 0.625"		19.05 mm / 0.750"		20.63 mm / 0.812"		22.22 mm / 0.875"		23.81 mm / 0.937"		25.40 mm / 1.000"		28.57 mm / 1.125"				
RPM		CFM	BHP	CFM	BHP	CFM	BHP	CFM	BHP	CFM	BHP	CFM	BHP	CFM	BHP	CFM	BHP	CFM	BHP	CFM	BHP	CFM	BHP	CFM	BHP	CFM	BHP	
		m³/hr	dB (A)	m³/hr	dB (A)	m³/hr	dB (A)	m³/hr	dB (A)	m³/hr	dB (A)	m³/hr	dB (A)	m³/hr	dB (A)	m³/hr	dB (A)	m³/hr	dB (A)	m³/hr	dB (A)	m³/hr	dB (A)	m³/hr	dB (A)	m³/hr	dB (A)	m³/hr
200		12900	1.32	11303	1.05	7824	0.62																					
		21930	71	19192	71	13285	65																					
215		14639	1.82	13352	1.53	11761	1.24																					
		24886	74	22672	74	19994	70																					
245		17900	3.11	16877	2.75	15805	2.42	13033	1.75	9505	1.12																	
		30430	78	28657	78	26869	75	22156	72	16139	72																	
265		19988	4.23	19057	3.81	18118	3.43	16003	2.72	14662	2.36	12780	1.91															
		33980	80	32359	80	30801	78	27205	76	24896	77	21700	76															
295		23053	6.33	22209	5.81	21386	5.35	19672	4.51	18735	4.11	17721	3.72	15023	2.86	12004	2.09											
		39190	83	37711	83	36356	81	33442	80	31812	81	30090	80	25539	76	20383	77											
315		25067	8.05	24263	7.45	23489	6.92	21922	5.98	21100	5.54	20248	5.12	18289	4.28	17060	3.82	15459	3.30									
		42614	84	41199	84	39931	83	37267	82	35828	83	34381	83	31091	80	28968	81	26249	80									
345		28057	11.2	27299	10.4	26579	9.8	25157	8.66	24437	8.14	23714	7.65	22173	6.72	21327	6.26	20419	5.81	19382	5.33	18169	4.81					
		47697	87	46354	87	45184	86	42767	85	41494	86	40266	85	37694	83	36213	84	34671	84	32911	83	30887	80					
360		29543	13.0	28802	12.2	28103	11.5	26734	10.2	26048	9.70	25367	9.15	23943	8.15	23182	7.67	22390	7.20	21522	6.71	20578	6.23	18137	5.11			
		50164	88	48906	88	47719	87	45394	86	44230	87	43073	86	40655	85	39363	86	38018	85	36544	85	34941	83	30797	83			
380		31515	15.7	30795	14.8	30119	14.0	28808	12.6	28158	12.0	27519	11.4	26208	10.3	25524	9.80	24828	9.30	24088	8.76	23316	8.26	21554	7.23			
		53576	89	52290	89	51202	88	48974	88	47812	88	46727	88	44554	87	43340	87	42158	87	40901	87	39637	85	36599	85			
390		32498	17.2	31788	16.2	31121	15.4	29835	13.9	29201	13.3	28579	12.6	27311	11.5	26657	10.9	25995	10.4	25298	9.88	24580	9.40	22989	8.33			
		55182	90	53976	90	52843	89	50660	89	49583	89	48527	89	46374	88	45264	88	44140	88	42956	87	41737	87	39035	86			

		PRESIÓN ESTÁTICA mmca / inwg																											
		31.75 mm / 1.250"		34.92 mm / 1.375"		38.10 mm / 1.500"		44.45 mm / 1.750"		47.62 mm / 1.875"		50.80 mm / 2.000"		58.72 mm / 2.312"		63.50 mm / 2.500"		69.85 mm / 2.750"		71.45 mm / 2.813"		76.20 mm / 3.000"		85.72 mm / 3.375"					
RPM		CFM	BHP	CFM	BHP	CFM	BHP	CFM	BHP	CFM	BHP	CFM	BHP	CFM	BHP	CFM	BHP	CFM	BHP	CFM	BHP	CFM	BHP	CFM	BHP	CFM	BHP		
		m³/hr	dB (A)	m³/hr	dB (A)	m³/hr	dB (A)	m³/hr	dB (A)	m³/hr	dB (A)	m³/hr	dB (A)	m³/hr	dB (A)	m³/hr	dB (A)	m³/hr	dB (A)	m³/hr	dB (A)	m³/hr	dB (A)	m³/hr	dB (A)	m³/hr	dB (A)	m³/hr	dB (A)
400		22637	8.40	20453	7.17	15647	4.94																						
		38438	87	34729	86	26569	81																						
415		24767	10.3	23049	9.10	20799	7.77																						
		42054	88	39137	87	35358	85																						
445		28578	14.4	27264	13.2	25796	12.0	21754	9.24																				
		48525	90	46294	90	43853	88	36982	85																				
465		30938	17.6	29765	16.3	28504	15.1	25496	12.5	23464	11.0	20082	8.86																
		52533	92	50541	91	48457	90	43343	88	39842	89	34139	85																
495		34324	23.0	33287	21.7	32207	20.3	29836	17.7	28477	16.4	26913	14.9																
		58282	94	56521	93	54752	92	50721	91	48354	92	45752	89																
515		36513	27.1	35539	25.7	34537	24.3	32404	21.5	31231	20.1	29951	18.8	25757	14.8														
		61999	95	60345	94	58713	93	55087	92	53030	93	50917	91	43735	91														
545		39725	34.1	38892	32.5	37905	30.9	36003	27.9	34999	26.5	33943	25.0	30925	21.3	28639	18.9	23434	14.2										
		67453	96	66039	96	64439	95	61205	95	59428	95	57703	94	52511	94	48686	92	39838	89										
565		41830	39.3	40963	37.6	40090	35.9	38299	32.7	37368	31.2	36403	29.7	33754	25.9	31910	23.6	28790	20.1	27764	19.1	3317	3.04						
		71027	97	69555	97	68153	96	65108	96	63451	96	61885	95	57314	95	54247	94	48943	92	47143	93	5639	70						
595		44948	48.0	44125	46.1	43302	44.2	41638	40.7	40788	39.1	39918	37.4	37613	33.5	36105	31.1	33831	27.9	33188	27.0	31004	24.3						
		76322	98	74924	98	73613	98	70785	98	69258	97	67861	97	63867	97	61379	96	57513	95	56353	95	52707	95						
600		45463	49.6	44647	47.6	43832	45.7	42185	42.2	41345	40.5	40488	38.8	38227	34.8	36758	32.4	34564	29.2	33950	28.4	31902	25.7	23471	16.7				
		77196	99	75811	98	74514	98	71715	98	70204	98	68830	97	64909	97	62489	96	58759	96	57647	96	54233	95	39854	92				

Condiciones Estándar: 0 m.s.n.m. y 20 °C



Los valores de caudal y presión están certificados para instalación tipo B: Sin ducto en la succión y ducto en la descarga. Estos valores no incluyen los efectos de accesorios. Los valores de potencia (BHP) no incluyen las pérdidas por transmisión.

Performance certified is for installation type B: free inlet, ducted outlet. Performance ratings does not include the effects of appurtenances (accessories). Power ratings (kW/BHP) does not include transmission losses.

CURVA CARACTERÍSTICA DA 30/28

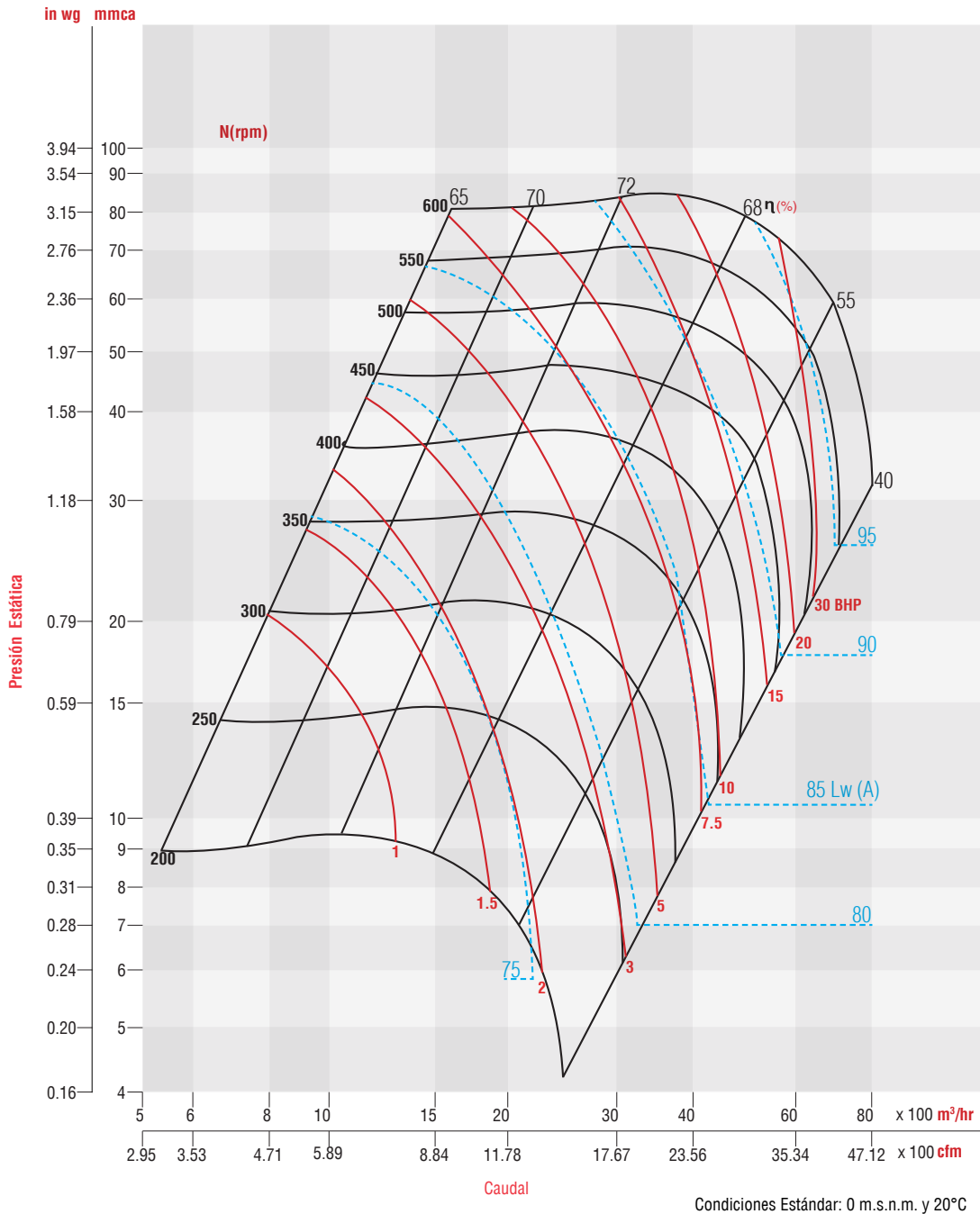

Los valores de caudal y presión están certificados para instalación tipo B: Sin ducto en la succión y ducto en la descarga. Estos valores no incluyen los efectos de accesorios. Los valores de potencia (BHP) no incluyen las pérdidas por transmisión.

Performance certified is for installation type B: free inlet, ducted outlet. Performance ratings does not include the effects of appurtenances (accessories). Power ratings (kW/BHP) does not include transmission losses.

CARACTERÍSTICAS PRINCIPALES DA 36/36

DA 36/36

RPM	PRESIÓN ESTÁTICA mmca / inwg																							
	6.35 mm / 0.250"		7.93 mm / 0.312"		9.53 mm / 0.375"		11.11 mm / 0.438"		12.70 mm / 0.500"		17.46 mm / 0.687"		19.05 mm / 0.750"		22.22 mm / 0.875"		25.40 mm / 1.000"		28.57 mm / 1.125"		31.75 mm / 1.250"		34.92 mm / 1.375"	
	CFM	BHP	CFM	BHP	CFM	BHP	CFM	BHP	CFM	BHP	CFM	BHP	CFM	BHP	CFM	BHP	CFM	BHP	CFM	BHP	CFM	BHP	CFM	BHP
	m³/hr	dB (A)	m³/hr	dB (A)	m³/hr	dB (A)	m³/hr	dB (A)	m³/hr	dB (A)	m³/hr	dB (A)	m³/hr	dB (A)	m³/hr	dB (A)	m³/hr	dB (A)	m³/hr	dB (A)	m³/hr	dB (A)	m³/hr	dB (A)
180	23217	3.34	21941	3.10	18207	2.37																		
	39422	78	37256	75	30915	72																		
200	26689	4.90	25742	4.56	24591	4.26	23098	4.02	18923	3.04														
	45318	82	43710	81	41756	78	39220	77	32132	74														
220	30005	6.86	29234	6.47	28792	6.34	28227	6.18	26119	5.52														
	50948	85	49639	84	48888	84	47929	82	44350	80														
240	33233	9.22	32810	8.99	32436	8.80	32215	8.79	31421	8.38	21731	4.74	19413	4.23										
	56430	87	55712	87	55076	87	54701	87	53353	85	36899	78	32963	77										
260	36403	12.0	35825	11.6	35388	11.3	35230	11.3	34549	10.8	31076	9.10	27098	7.33	20604	5.20								
	61812	90	60831	89	60089	89	59820	89	58664	89	52767	84	46012	82	34986	79								
280	39533	15.3	39016	14.9	38581	14.5	38230	14.3	38107	14.3	36964	10.2	34206	11.7	29260	9.23	23703	7.10						
	67127	92	66249	92	65510	91	64915	91	64705	91	62765	89	58082	86	49683	84	40247	82						
300	42635	19.1	42165	18.6	41847	18.4	41647	18.3	41147	17.6	40044	16.9	39595	16.6	36450	14.3	31692	11.6	27176	9.58				
	72394	94	71596	94	71056	93	70717	93	69868	93	67995	93	67232	92	61892	88	53813	86	46145	84				
320	45714	23.5	45284	22.4	44831	22.4	44360	21.9	43876	21.4	43299	21.4	42833	20.6	42214	20.2	38820	17.3	34310	14.3	29034	11.5		
	77622	96	76892	95	76123	95	75323	95	74501	95	73522	95	72731	95	71679	93	65916	90	58258	88	49300	86		
340	48776	28.4	48379	27.9	47962	27.3	47531	26.8	47092	26.2	46590	25.9	46124	25.4	45781	25.2	44619	24.0	41296	20.8	37047	17.6	33604	15.6
	82822	97	82148	97	81439	97	80708	97	79962	97	79110	97	78319	97	77736	97	75763	95	70121	92	62906	89	57060	88
350	50302	31.1	49919	30.6	49518	30.0	49104	29.5	48684	28.9	48109	28.4	47862	28.2	46988	20.2	45816	25.7	44846	25.0	40724	21.2	37146	18.6
	85413	98	84762	98	84082	98	83379	98	82665	98	81689	98	81269	98	79785	98	77795	96	76148	94	69150	92	63074	90

RPM	PRESIÓN ESTÁTICA mmca / inwg																							
	38.10 mm / 1.500"		46.03 mm / 1.813"		50.80 mm / 2.000"		52.38 mm / 2.062"		66.67 mm / 2.625"		76.20 mm / 3.000"		82.55 mm / 3.250"		100.01 mm / 3.987"		101.60 mm / 4.000"		120.65 mm / 4.750"		127.00 mm / 5.000"		133.30 mm / 5.250"	
	CFM	BHP	CFM	BHP	CFM	BHP	CFM	BHP	CFM	BHP	CFM	BHP	CFM	BHP	CFM	BHP	CFM	BHP	CFM	BHP	CFM	BHP	CFM	BHP
	m³/hr	dB (A)	m³/hr	dB (A)	m³/hr	dB (A)	m³/hr	dB (A)	m³/hr	dB (A)	m³/hr	dB (A)	m³/hr	dB (A)	m³/hr	dB (A)	m³/hr	dB (A)	m³/hr	dB (A)	m³/hr	dB (A)	m³/hr	dB (A)
375	42708	25.3	32444	17.6																				
	72518	93	55090	90																				
400	51097	37.2	45287	31.3	35381	21.7	31445	18.0																
	86762	97	76897	95	60077	91	53394	90																
440	58490	53.0	56079	49.1	50720	41.5	49563	40.0																
	99316	102	95222	99	86122	97	84158	97																
470	62980	65.1	61845	63.3	61182	62.6	60452	61.1	45890	40.0														
	106940	104	105013	103	103887	102	102647	101	77921	96														
500	68389	82.2	67102	79.2	66406	77.9	66244	77.7	58942	63.9	50089	50.7	40984	38.6										
	116125	106	113939	106	112757	105	112482	105	100084	101	85051	98	69591	96										
540	73396	100.5	73041	100.4	72830	97.3	72710	100.5	69993	93.7	64220	81.4	57741	68.6										
	124626	107	124023	107	123665	107	123462	108	118848	105	109046	103	98044	101										
570	79710	123.8	78948	122.8	77733	116.5	77611	120.3	74506	111.8	71528	103.8	68481	97.0	53231	67.7	49792	61.4						
	135347	109	134054	109	131991	108	131784	109	126511	107	121454	104	116280	102	90386	100	84546	100						
600	85208	148.1	83660	144.7	83621	140.9	82388	142.3	81030	137.6	77184	126.1	75939	123.3	65941	98.7	64640	95.9						
	144683	110	142054	110	141989	110	139895	110	137589	108	131058	106	128945	104	111968	104	109758	104						
640	91572	181.9	91042	181.4	90680	175.6	90178	180.1	88069	172.2	85970	164.4	84099	159.1	76826	138.6	76384	137.9	62834	100.5	57734	93.8	48598	100.5
	155489	112	154589	112	153975	111	153122	112	149542	110	145977	108	142800	105	130451	106	129700	106	106692	104	98032	103	82519	104
650	94294	194.9	93567	193.8	93084	187.2	92988	193.5	91317	186.6	88855	177.2	87700	174.2	80064	151.5	79675	150.9	70395	123.8	61348	100.5	57833	123.8
	160112	112	158877	112	158056	112	157893	112	155056	110	150875	108	148914	106	135949	107	135288	107	119531	105	104169	104	98200	105

Condiciones Estándar: 0 m.s.n.m. y 20 °C



Los valores de caudal y presión están certificados para instalación tipo B: Sin ducto en la succión y ducto en la descarga. Estos valores no incluyen los efectos de accesorios. Los valores de potencia (BHP) no incluyen las pérdidas por transmisión.

Performance certified is for installation type B: free inlet, ducted outlet. Performance ratings does not include the effects of appurtenances (accessories). Power ratings (kW/BHP) does not include transmission losses.

CURVA CARACTERÍSTICA DA 36/36

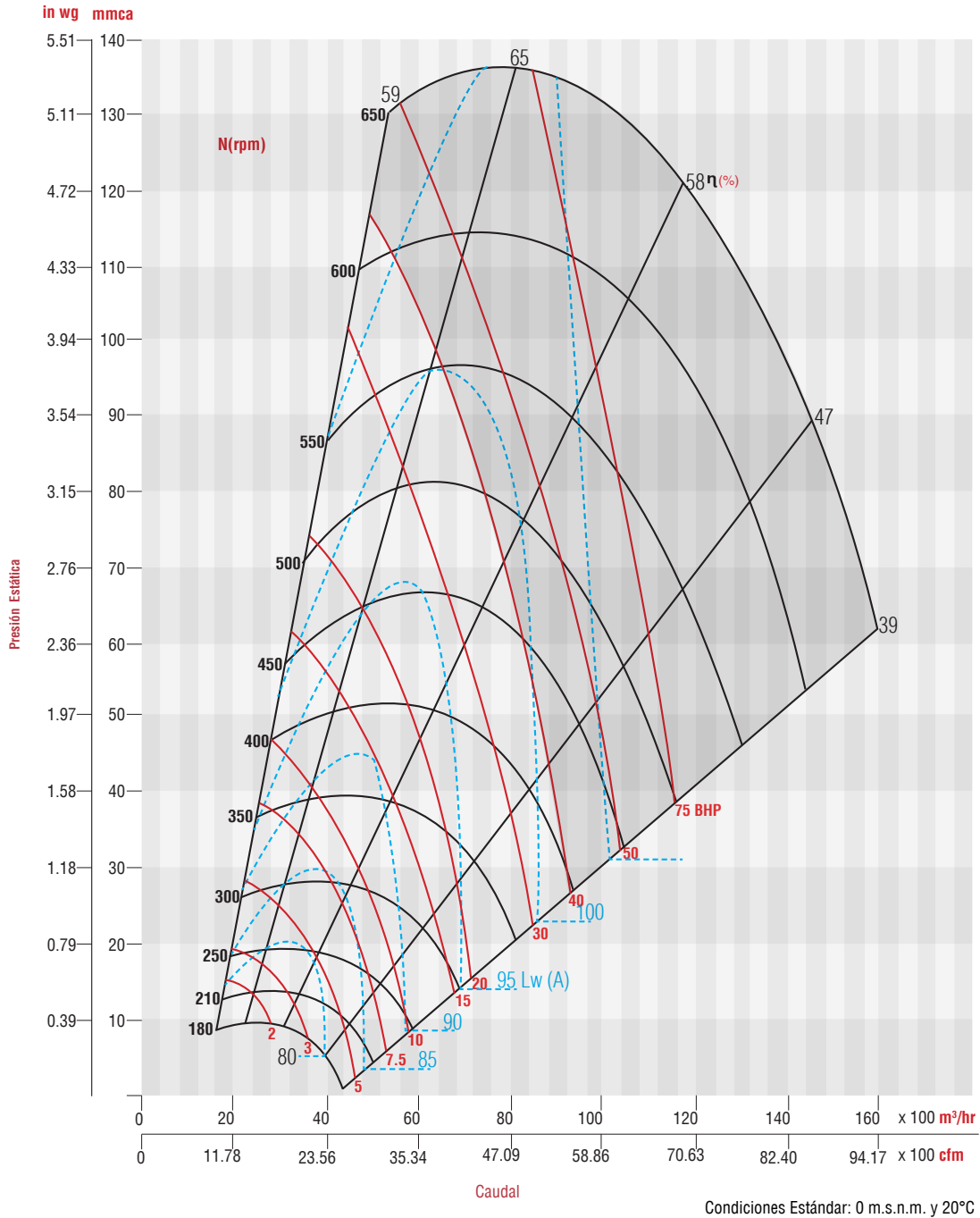

Los valores de caudal y presión están certificados para instalación tipo B: Sin ducto en la succión y ducto en la descarga. Estos valores no incluyen los efectos de accesorios. Los valores de potencia (BHP) no incluyen las pérdidas por transmisión.

Performance certified is for installation type B: free inlet, ducted outlet. Performance ratings does not include the effects of appurtenances (accessories). Power ratings (kW/BHP) does not include transmission losses.

DIMENSIONES DA - DA/B DA: 7-7 al 18-18 (Únicamente hasta 3 HP)

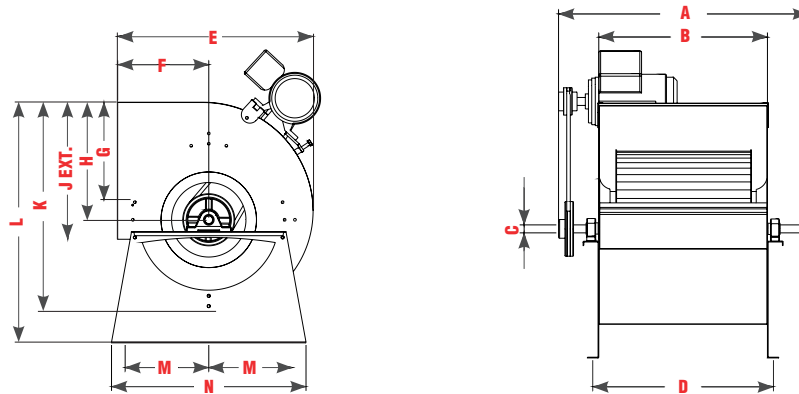

MODELO	A	B	C	D	E	F	G	H	J	K	L	M	N
7/7	440	232	19	334	307	147	145	180	219	320	370	120	294
9/9	530	300	19	334	380	184	180	218	260	392	491	150	380
10/10	580	333	19	430	420	201	213	247	286	442	512	180	400
12/12	625	396	22	430	493	229	240	293	341	524	629	203	485
15/15	700	473	22	507	573	267	270	343	403	613	731	245	570
18/18	790	556	22	590	685	314	290	418	479	743	881	300	680

Dimensiones en mm.

MODELO	A	B	C	D	E	F	G	H	J	K	L	M	N
7/7	17 5/16	9 1/8	3/4	13 1/8	12 1/6	5 13/16	5 11/16	7 1/16	8 5/8	12 5/8	14 9/16	4 3/4	11 9/16
9/9	20 7/8	11 13/16	3/4	13 1/8	14 15/16	7 1/4	7 1/16	8 9/16	10 1/4	15 7/16	19 5/16	5 7/8	14 15/16
10/10	22 13/16	13 1/8	3/4	16 15/16	16 9/16	7 15/16	8 3/8	9 3/4	11 1/4	17 3/8	20 3/16	7 1/16	15 3/4
12/12	24 5/8	15 9/16	7/8	16 15/16	19 7/16	9	9 7/16	11 9/16	13 7/16	20 5/8	24 3/4	8	19 1/8
15/15	27 9/16	18 5/8	7/8	19 15/16	22 9/16	10 1/2	10 5/8	13 1/2	15 7/8	24 1/8	28 3/4	9 5/8	22 7/16
18/18	31 1/8	21 7/8	7/8	23 1/4	26 15/16	12 3/8	11 7/16	16 7/16	18 7/8	29 1/4	34 11/16	11 13/16	26 3/4

Dimensiones en pulgadas

DA/B: 7-7 al 18-18

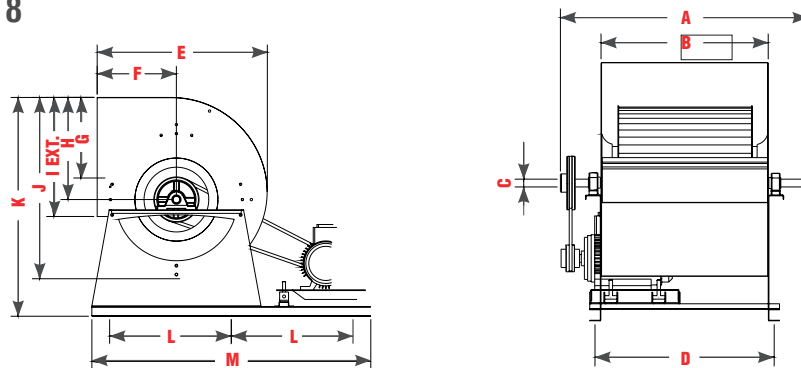

MODELO	A	B	C	D	E	F	G	H	I	J	K	L	M
7/7	440	232	19	334	307	147	145	180	219	320	390	315	750
9/9	530	300	19	334	380	184	180	218	260	392	511	315	750
10/10	580	333	19	430	420	201	213	247	286	442	532	367	855
12/12	625	396	22	430	493	229	240	293	341	524	649	367	855
15/15	700	473	22	507	573	267	270	343	403	613	751	410	940
18/18	790	556	22	590	685	314	290	418	479	743	901	465	1050

Dimensiones en mm.

MODELO	A	B	C	D	E	F	G	H	I	J	K	L	M
7/7	17 5/16	9 1/8	3/4	13 1/8	12 1/6	5 13/16	5 11/16	7 1/16	8 5/8	12 5/8	15 3/8	12 3/8	29 1/2
9/9	20 7/8	11 13/16	3/4	13 1/8	14 15/16	7 1/4	7 1/16	8 9/16	10 1/4	15 7/16	20 1/8	12 3/8	29 1/2
10/10	22 13/16	13 1/8	3/4	16 15/16	16 9/16	7 15/16	8 3/8	9 3/4	11 1/4	17 3/8	20 15/16	14 7/16	33 11/16
12/12	24 5/8	15 9/16	7/8	16 15/16	19 7/16	9	9 7/16	11 9/16	13 7/16	20 5/8	25 9/16	14 7/16	33 11/16
15/15	27 9/16	18 5/8	7/8	19 15/16	22 9/16	10 1/2	10 5/8	13 1/2	15 7/8	24 1/8	29 9/16	16 1/8	37
18/18	31 1/8	21 7/8	7/8	23 1/4	26 15/16	12 3/8	11 7/16	16 7/16	18 7/8	29 1/4	35 1/2	18 5/16	41 5/16

Dimensiones en mm.

DA: 20-20 al 30-28

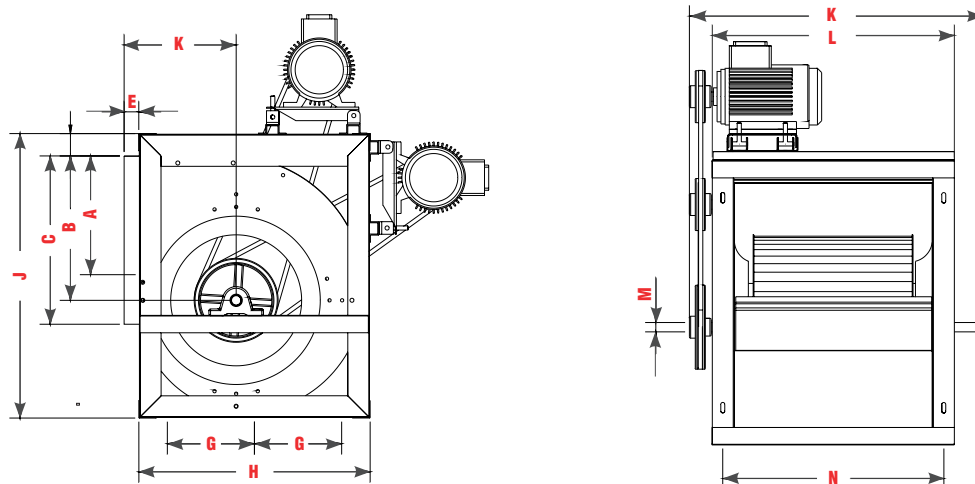

MODELO	A	B	C	D	E	F	G	H	J	K	L	M	N
20/20	340	526	630	55	50	361	326	772	967	930	730	34.9	680
22/22	390	580	697	55	56	394	326	862	1070	1004	796	34.9	746
25/25	430	649	795	55	56	438	382	973	1203	1110	896	34.9	846
30/28	485	765	940	55	52	510	474	1158	1418	1185	970	34.9	920

Dimensiones en mm.

MODELO	A	B	C	D	E	F	G	H	J	K	L	M	N
20/20	13 3/8	20 11/16	24 13/16	2 3/16	1 15/16	14 3/16	12 13/16	30 3/8	38 1/16	36 5/8	28 3/4	1 3/8	26 3/4
22/22	15 3/8	22 13/16	27 7/16	2 3/16	2 3/16	15 1/2	12 13/16	33 15/16	42 1/8	39 1/2	31 5/16	1 3/8	29 3/8
25/25	16 15/16	25 9/16	31 5/16	2 3/16	2 3/16	17 1/4	15	38 5/16	47 3/8	43 11/16	35 1/4	1 3/8	33 5/16
30/28	19 1/8	30 1/8	37	2 3/16	2 1/16	20 1/16	18 11/16	45 9/16	55 13/16	46 5/8	38 3/16	1 3/8	36 1/4

Dimensiones en pulgadas

AVB: 20-20 al 30-28

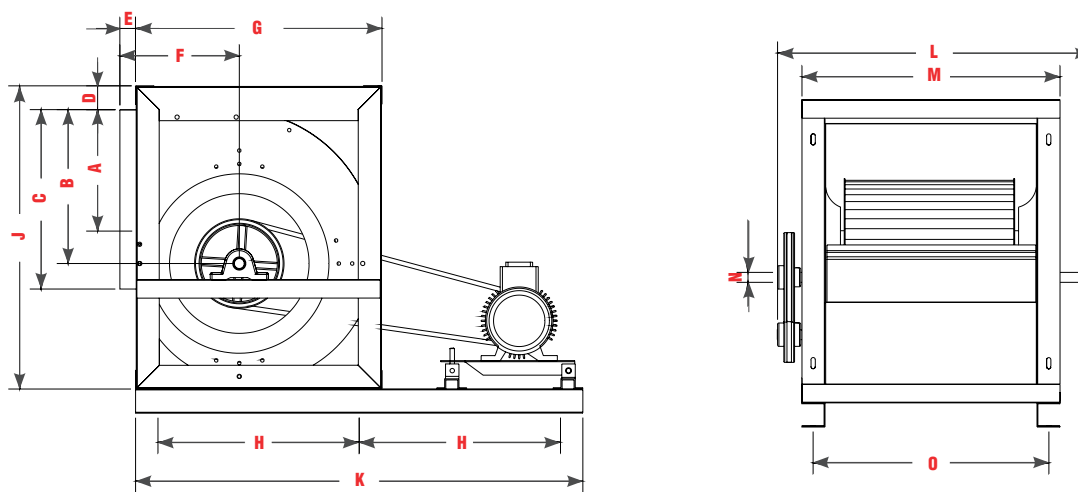

MODELO	A	B	C	D	E	F	G	H	J	K	L	M	N	O
20/20	340	526	630	55	50	361	772	511	967	1222	930	730	35	680
22/22	390	580	697	55	56	394	862	552	1070	1303	1004	796	35	746
25/25	430	649	795	55	56	438	973	630	1203	1460	1110	896	35	846
30/28	485	765	940	55	52	510	1158	724	1418	1648	1185	970	35	920

Dimensiones en mm.

MODELO	A	B	C	D	E	F	G	H	J	K	L	M	N	O
20/20	13 3/8	20 11/16	24 13/16	2 3/16	1 15/16	14 3/16	30 3/8	20 1/8	38 1/16	48 1/8	36 5/8	28 3/4	1 3/8	26 3/4
22/22	15 3/8	22 13/16	27 7/16	2 3/16	2 3/16	15 1/2	33 15/16	21 11/16	42 1/8	51 5/16	39 1/2	31 5/16	1 3/8	29 3/8
25/25	16 15/16	25 9/16	31 5/16	2 3/16	2 3/16	17 1/4	38 5/16	24 13/16	47 3/8	57 1/2	43 11/16	35 1/4	1 3/8	33 5/16
30/28	19 1/8	30 1/8	37	2 3/16	2 1/16	20 1/16	45 9/16	28 1/2	55 13/16	64 7/8	46 5/8	38 3/16	1 3/8	36 1/4

Dimensiones en pulgadas

DA: 36/36

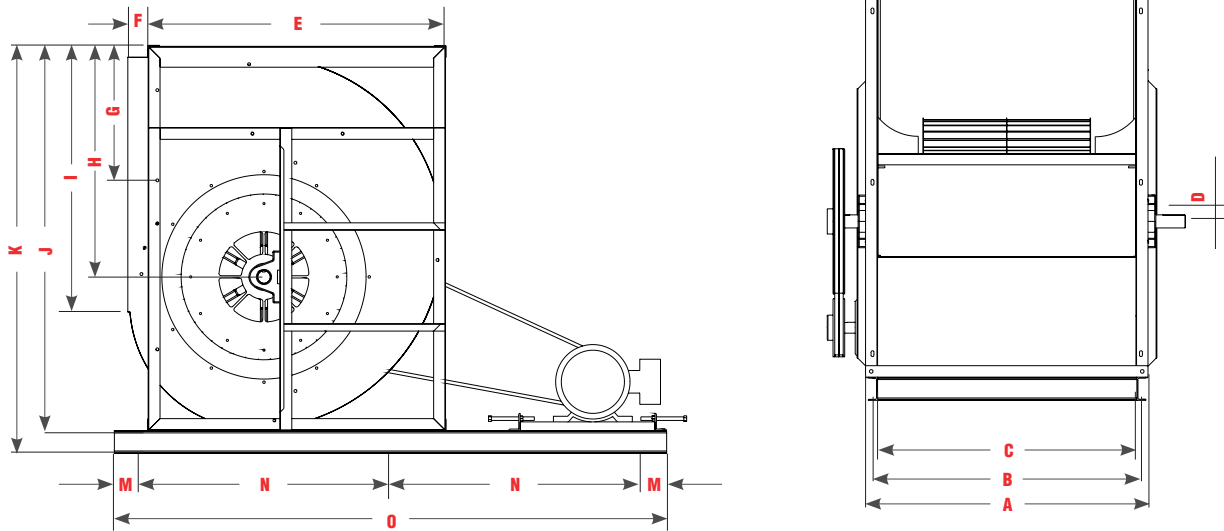

MODELO	A	B	C	D	E	F	G	H	I	J	K	L	M	N	O
DAB 36/36	1235	1174	1130	57	1324	90	704	974	1130	1708	1080	51	115	1110	2450

Dimensiones en mm.

MODELO	A	B	C	D	E	F	G	H	I	J	K	L	M	N	O
DAB 36/36	48 5/8	46 1/4	44 1/2	2 1/4	52 1/8	3 9/16	27 11/16	38 3/8	44 1/2	67 1/4	42 1/2	2	4 1/2	43 11/16	96 7/16

Dimensiones en pulgadas

** 3 segmentos.

* Solicitar dibujo de brida de descarga a fábrica.

ACCESORIOS PARA CONTROL DE VIBRACIÓN Y RUIDO

Dentro de las líneas que S&P ofrece, se encuentra la línea de tacones de hule y resortes especiales para el aislamiento de vibración y ruido.



-Tacones de hule: Ideales para eliminar vibraciones de alta frecuencia.

-Resortes S&P: Medio más eficiente para control de vibración debido a su capacidad de deflexión

CONECTOR FLEXIBLE DE LONA



Accesorio recomendado para aislamiento de vibraciones en instalaciones de HVAC. Fabricado con 35 mm de lámina galvanizada calibre 28 en cada extremo y 60 mm de una base poliéster con recubrimiento de PVC por ambos lados.

Rango de temperatura de funcionamiento de -30°C a 80°C, además de ser retardante de flama. Facilita la instalación de los equipos, al estar listo para ser colocado en campo.

ACCESORIOS PARA CONTROL Y AUTOMATIZACIÓN



Accesorios de gran alcance, hechos para el control y correcta manipulación de los equipos en la puesta en marcha y paro de los mismos, los cuales permiten un mejor acceso a la conexión, y aumentan la seguridad.

Características:

Factor de protección IP 65, material PBT resistente a UV:F1 (UL746C), alambre incandescente 850°C (IEC 60 695-2-12), terminales aisladas, tapa bloqueada en posición ON, terminal de tierra incluida y las terminales de fuerza y tierra cuentan con factor de protección IP 20.

VENTILADORES

DAT | Centrífugos
Alabes Adelantados

TIPO TWIN



DIMENSIONES DAT:10/10, 12/12 y 15/15

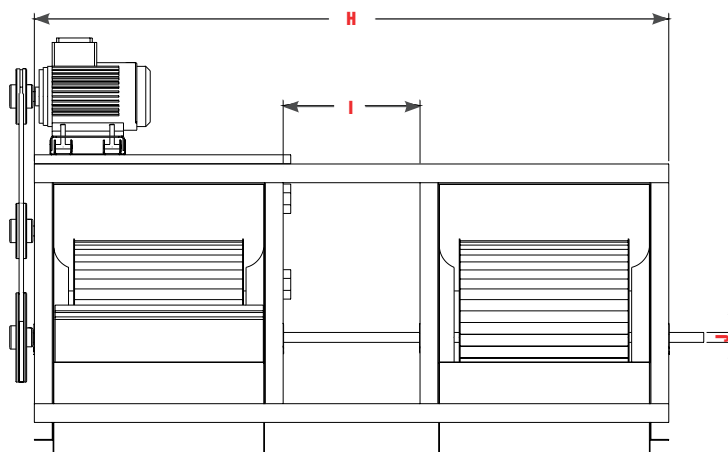
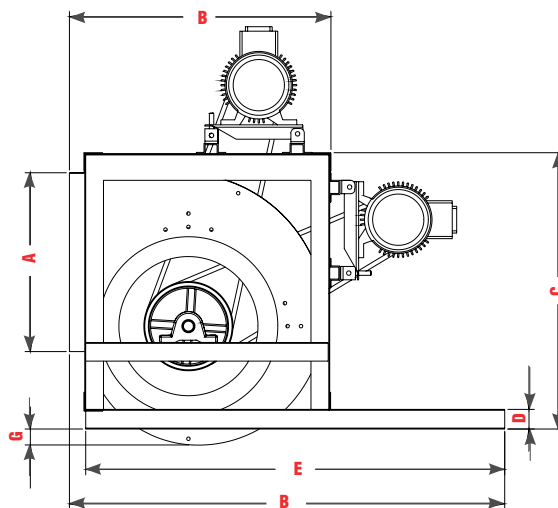

MODELO	A	B	C	D	E	F	G	H	I	J
DAT-10/10	284	393	442	44	791	819	22	1006	218	19.05
DAT-12/12	336	455	522	44	853	893	29	1171	254	25.4
DAT-15/15	400	587	618	44	940	976	36	1423	321	25.4

Dimensiones en mm.

MODELO	A	B	C	D	E	F	G	H	I	J
DAT-10/10	11 3/16	15 1/2	17 3/8	1 3/4	31 1/8	32 1/4	7/8	39 5/8	8 9/16	3/4
DAT-12/12	13 1/4	17 15/16	20 9/16	1 3/4	33 9/16	35 3/16	1 1/8	46 1/8	10	1
DAT-15/15	15 3/4	23 1/8	24 5/16	1 3/4	37	38 7/16	1 7/16	56	12 5/8	1

Dimensiones en pulgadas

** 3 segmentos.

* Solicitar dibujo de brida de descarga a fábrica.

RECUBRIMIENTOS

APLICACIÓN ESTÁNDAR

Pintura en polvo poliéster

La pintura estándar S&P, es ideal para aplicaciones comerciales e industriales, donde los contaminantes corrosivos sean de moderados a bajos.

Su aplicación consiste en partículas de pigmento y resinas, que mediante un proceso electrostático se adhieren a la superficie del metal, previamente desengrasado, fosfatizado y decapado; posteriormente mediante alta temperatura obtiene sus características de acabado liso, uniforme, dureza, resistencia a impacto, resistencia química y a la abrasión adecuada con gran resistencia a agentes corrosivos (hasta 800 horas de Cámara Salina de acuerdo a corrosión ASTM B-117, Ampollamiento ASTM D-714 y Adherencia ASTM D-1654).

RECUBRIMIENTOS ESPECIALES

Cuando el uso de un ventilador se destina a aplicaciones industriales, donde el ambiente en el que operará es altamente corrosivo, es recomendable aplicar algún recubrimiento especial que pueda resistir este tipo de atmósferas.

Para ello Soler & Palau pone a su disposición acabados especiales:

PINTURA EPÓXICA ALTOS SÓLIDOS

Recubrimiento epóxico de dos componentes curado con poliamida, modificado con amina.

Este es un recubrimiento especial para S&P, pudiendo ser usado como primario, enlace acabado o como recubrimiento único. Su uso en ventiladores es ideal ya que aplicado a piezas metálicas sometidas a humedad o inmersión ofrece gran resistencia. Su adherencia es excelente en cualquier tipo de acero, incluyendo los que tengan acabados galvanizados. Es un producto versátil altos sólidos que posee excelentes propiedades recomendado para ambientes corrosivos severos. Su apariencia es semimate y el color es caqui. Obteniendo un total de 1000 horas cámara salina.

Resistencia química:

Ácido	Muy bueno	Abración	Excelente	Inemperie	Muy bueno
Álcalis	Excelente	Solventes	Excelente		
Humedad	Excelente	Sales	Excelente		

Importante: Este producto es susceptible al caleo debido a la radiación UV. Temperatura máxima de servicio: 93 °C servicio continuo y 148 °C intermitente.

RECUBRIMIENTOS

PINTURA EN POLVO POLIESTER DE ALTA RESISTENCIA

Pintura de tipo especial, el cuál es usado como recubrimiento único, fabricado especial para el cuidado del sustrato, debido a su alta resistencia a la corrosión y excelente nivel de adherencia.

Su aplicación es mediante el curado y su acabado es liso, con excelente nivel de dureza, flexibilidad , resistencia al impacto y abrasión. Recomendado para sitios donde el nivel de humedad y rocío salino sean altos.

Resistencia química:

Ácido	Muy bueno	Abración	Excelente
Álcalis	Excelente	Sales	Excelente
Humedad	Excelente	Inemperie	Muy bueno

Recubrimientos fenólicos secado al aire

Este acabado es especial y se sugiere consultar a fábrica para condiciones comerciales.

Ofrecen excelente resistencia a humos que contengan ácidos, bases, sales inorgánicas y solventes.

Buena resistencia para condensados y espreado de estos componentes.

Recubrimiento para alta temperatura

Este acabado es especial y se sugiere consultar a fábrica para condiciones comerciales. Para aplicaciones donde las temperaturas sobrepasan los 150°C color Aluminio.



www.solerpalau.mx

S&P México

Tel. 52 (222) 2 233 911, 2 233 900
comercialmx@solerpalau.com

S&P Colombia

PBX: (+571 743 8021)
comercial@solerpalau.com.co

S&P Perú

Tel. +51 (1) 200 9020
comercialpe@solerpalau.com



ISO 9001:2015
S&P México se reserva el derecho
de modificación sin previo aviso.